



SUPERSERVER®

6018R-MT  
6018R-MTR



Revision 1.0b

The information in this User's Manual has been carefully reviewed and is believed to be accurate. The vendor assumes no responsibility for any inaccuracies that may be contained in this document, makes no commitment to update or to keep current the information in this manual, or to notify any person or organization of the updates. **Please Note: For the most up-to-date version of this manual, please see our web site at [www.supermicro.com](http://www.supermicro.com).**

Super Micro Computer, Inc. ("Supermicro") reserves the right to make changes to the product described in this manual at any time and without notice. This product, including software and documentation, is the property of Supermicro and/or its licensors, and is supplied only under a license. Any use or reproduction of this product is not allowed, except as expressly permitted by the terms of said license.

IN NO EVENT WILL SUPERMICRO BE LIABLE FOR DIRECT, INDIRECT, SPECIAL, INCIDENTAL, SPECULATIVE OR CONSEQUENTIAL DAMAGES ARISING FROM THE USE OR INABILITY TO USE THIS PRODUCT OR DOCUMENTATION, EVEN IF ADVISED OF THE POSSIBILITY OF SUCH DAMAGES. IN PARTICULAR, SUPERMICRO SHALL NOT HAVE LIABILITY FOR ANY HARDWARE, SOFTWARE, OR DATA STORED OR USED WITH THE PRODUCT, INCLUDING THE COSTS OF REPAIRING, REPLACING, INTEGRATING, INSTALLING OR RECOVERING SUCH HARDWARE, SOFTWARE, OR DATA.

Any disputes arising between manufacturer and customer shall be governed by the laws of Santa Clara County in the State of California, USA. The State of California, County of Santa Clara shall be the exclusive venue for the resolution of any such disputes. Super Micro's total liability for all claims will not exceed the price paid for the hardware product.

FCC Statement: This equipment has been tested and found to comply with the limits for a Class A digital device pursuant to Part 15 of the FCC Rules. These limits are designed to provide reasonable protection against harmful interference when the equipment is operated in a commercial environment. This equipment generates, uses, and can radiate radio frequency energy and, if not installed and used in accordance with the manufacturer's instruction manual, may cause harmful interference with radio communications. Operation of this equipment in a residential area is likely to cause harmful interference, in which case you will be required to correct the interference at your own expense.

California Best Management Practices Regulations for Perchlorate Materials: This Perchlorate warning applies only to products containing CR (Manganese Dioxide) Lithium coin cells. "Perchlorate Material-special handling may apply. See [www.dtsc.ca.gov/hazardouswaste/perchlorate](http://www.dtsc.ca.gov/hazardouswaste/perchlorate)"

**WARNING: Handling of lead solder materials used in this product may expose you to lead, a chemical known to the State of California to cause birth defects and other reproductive harm.**

Manual Revision 1.0b  
Release Date: March 14, 2019

Unless you request and receive written permission from Super Micro Computer, Inc., you may not copy any part of this document.

Information in this document is subject to change without notice. Other products and companies referred to herein are trademarks or registered trademarks of their respective companies or mark holders.

Copyright © 2019 by Super Micro Computer, Inc.  
All rights reserved.  
**Printed in the United States of America**

# Preface

## About This Manual

This manual is written for professional system integrators and PC technicians. It provides information for the installation and use of the SuperServer 6018R-MT/6018R-MTR. Installation and maintenance should be performed by experienced technicians only.

The SuperServer 6018R-MT/6018R-MTR is a 1U rackmount server based on the SC813MFTQ-400CB/R400CB server chassis and the Super X10DRL-i serverboard. Please refer to our web site for updates on supported processors.

## Manual Organization

### Chapter 1: Introduction

The first chapter provides a checklist of the main components included with the server system and describes the main features of the Super X10DRL-i serverboard and the SC813MFTQ-400CB/R400CB chassis.

### Chapter 2: Server Installation

This chapter describes the steps necessary to install the SuperServer 6018R-MT/6018R-MTR into a rack and check out the server configuration prior to powering up the system. If your server was ordered without the processor and memory components, this chapter will refer you to the appropriate sections of the manual for their installation.

### Chapter 3: System Interface

Refer to this chapter for details on the system interface, which includes the functions and information provided by the control panel on the chassis as well as other LEDs located throughout the system.

## **Chapter 4: Standardized Warning Statements**

You should thoroughly familiarize yourself with this chapter for a general overview of safety precautions that should be followed when installing and servicing the SuperServer 6018R-MT/6018R-MTR.

## **Chapter 5: Advanced Serverboard Setup**

Chapter 5 provides detailed information on the X10DRL-i serverboard, including the locations and functions of connectors, headers and jumpers. Refer to this chapter when adding or removing processors or main memory and when reconfiguring the serverboard.

## **Chapter 6: Advanced Chassis Setup**

Refer to Chapter 6 for detailed information on the SC813MFTQ-400CB/R400CB chassis. You should follow the procedures given in this chapter when installing, removing or reconfiguring Serial ATA or peripheral drives and when replacing system power supply units and cooling fans.

## **Chapter 7: BIOS**

The BIOS chapter includes an introduction to BIOS and provides detailed information on running the CMOS Setup Utility.

## **Appendix A: BIOS POST Error Codes**

## **Appendix B: System Specifications**

## Notes

## Table of Contents

### **Chapter 1 Introduction**

1-1	Overview .....	1-1
1-2	Serverboard Features .....	1-2
	Processors .....	1-2
	Memory .....	1-2
	SATA .....	1-2
	PCI Expansion Slots .....	1-2
	I/O Ports .....	1-2
1-3	Server Chassis Features .....	1-3
	System Power .....	1-3
	SATA Subsystem .....	1-3
	Control Panel .....	1-3
	Cooling System .....	1-3
1-4	Contacting Supermicro .....	1-5

### **Chapter 2 Server Installation**

2-1	Overview .....	2-1
2-2	Unpacking the System .....	2-1
2-3	Preparing for Setup .....	2-1
	Choosing a Setup Location .....	2-1
2-4	Warnings and Precautions .....	2-2
	Rack Precautions .....	2-2
	Server Precautions .....	2-2
	Rack Mounting Considerations .....	2-3
	Ambient Operating Temperature .....	2-3
	Reduced Airflow .....	2-3
	Mechanical Loading .....	2-3
	Circuit Overloading .....	2-3
	Reliable Ground .....	2-3
2-5	Installing the System into a Rack .....	2-4
	Identifying the Sections of the Rack Rails .....	2-4
	Installing the Rear Inner Rails .....	2-4
	Installing the Rack Rails .....	2-5
	Installing the Server into the Rack .....	2-6
	Installing the Server into a Telco Rack .....	2-7

---

**Chapter 3 System Interface**

3-1	Overview .....	3-1
3-2	Control Panel Buttons .....	3-1
	Reset .....	3-1
	Power .....	3-1
3-3	Control Panel LEDs .....	3-2
	Information LED .....	3-2
	NIC2 .....	3-2
	NIC1 .....	3-2
	HDD .....	3-2
	Power .....	3-3
3-4	Hard Drive Carrier LEDs .....	3-3

**Chapter 4 Standardized Warning Statements for AC Systems**

4-1	About Standardized Warning Statements .....	4-1
	Warning Definition .....	4-1
	Installation Instructions .....	4-4
	Circuit Breaker .....	4-5
	Power Disconnection Warning .....	4-6
	Equipment Installation .....	4-8
	Restricted Area .....	4-9
	Battery Handling .....	4-10
	Redundant Power Supplies .....	4-12
	Backplane Voltage .....	4-13
	Comply with Local and National Electrical Codes .....	4-14
	Product Disposal .....	4-15
	Hot Swap Fan Warning .....	4-16
	Power Cable and AC Adapter .....	4-18

**Chapter 5 Advanced Serverboard Setup**

5-1	Handling the Serverboard .....	5-1
	Precautions .....	5-1
	Unpacking .....	5-2
5-2	Connecting Cables .....	5-2
	Connecting Data Cables .....	5-2
	Connecting Power Cables .....	5-2
	Connecting the Control Panel .....	5-2
5-3	Rear I/O Ports .....	5-3
5-4	Installing the Processor and Heatsink .....	5-4
	Installing an LGA 2011 Processor .....	5-4

---

	Installing a Passive CPU Heatsink .....	5-7
	Removing the Heatsink .....	5-7
5-5	Installing Memory Modules .....	5-8
	Installing & Removing DIMMs.....	5-8
	Memory Support for the X10DRL-i Serverboard.....	5-9
5-6	Adding PCI Cards .....	5-10
5-7	Serverboard Details .....	5-11
	X10DRL-i Quick Reference Table.....	5-11
5-8	Connector Definitions .....	5-13
	ATX Power Connector.....	5-13
	Processor Power Connector .....	5-13
	Power Button.....	5-13
	Reset Button.....	5-13
	Power Fail LED .....	5-14
	Overheat (OH)/Fan Fail/PWR Fail/UID LED .....	5-14
	NIC2 (LAN2) LED.....	5-14
	NIC1 (LAN1) LED.....	5-14
	HDD LED.....	5-14
	Power On LED .....	5-15
	NMI Button .....	5-15
	Fan Headers.....	5-15
	Chassis Intrusion.....	5-15
	Serial Ports.....	5-15
	Universal Serial Bus (USB).....	5-16
	Power SMB (I <sup>2</sup> C) Connector .....	5-16
	IPMB.....	5-16
	SGPIO Headers .....	5-17
	DOM Power Connector .....	5-17
	TPM/Port 80 Header .....	5-17
	Onboard Speaker (SP1).....	5-17
	LAN1/2 (Ethernet Ports).....	5-18
	Unit Identifier Switch/UID LED Indicators .....	5-18
	Power LED/Speaker.....	5-19
	Standby Power Header .....	5-19
5-9	Jumper Settings .....	5-20
	Explanation of Jumpers .....	5-20
	CMOS Clear .....	5-20
	BMC Enable .....	5-20
	LAN1/LAN2 Enable/Disable .....	5-21

---



---

---

	VGA Enable/Disable .....	5-21
	Watch Dog .....	5-21
	I <sup>2</sup> C Bus to PCI/PCI-Exp. Slots .....	5-21
	ME Manufacturing Mode Select .....	5-21
5-10	Onboard Indicators .....	5-22
	LAN Port LEDs .....	5-22
	Rear UID LED .....	5-22
	Onboard Power LED .....	5-22
	BMC Heartbeat LED .....	5-22
5-11	SATA Ports .....	5-23
	SATA 3.0 Ports .....	5-23
5-12	Installing Software .....	5-24
	SuperDoctor® 5 .....	5-25
5-13	Onboard Battery .....	5-26

## **Chapter 6 Advanced Chassis Setup**

6-1	Static-Sensitive Devices .....	6-1
	Precautions .....	6-1
	Unpacking .....	6-1
6-2	Control Panel .....	6-2
6-3	System Fans .....	6-3
6-4	Drive Bay Installation/Removal .....	6-3
	Removing the Front Bezel .....	6-3
	SATA Drive Installation .....	6-4
	Accessing the Drive Bays .....	6-4
	SATA Backplane .....	6-5
6-5	Power Supply .....	6-7
	6018R-MT .....	6-7
	Power Supply Failure .....	6-7
	6018R-MTR .....	6-8
	Power Supply Failure .....	6-8

## **Chapter 7 BIOS**

7-1	Introduction .....	7-1
	Starting BIOS Setup Utility .....	7-1
	How To Change the Configuration Data .....	7-1
	How to Start the Setup Utility .....	7-2
7-2	Main Setup .....	7-2
7-3	Advanced Setup Configurations .....	7-4
7-4	Event Logs .....	7-34

---

7-5	IPMI .....	7-36
7-6	Security Settings .....	7-38
7-7	Boot Settings.....	7-39
7-8	Save & Exit .....	7-42

***Appendix A BIOS Error Beep Codes***

***Appendix B System Specifications***

# Chapter 1

## Introduction

### 1-1 Overview

The SuperServer 6018R-MT/6018R-MTR is comprised of two main subsystems: the SC813MFTQ-400CB/R400CB 1U chassis and the X10DRL-i serverboard. Please refer to our website for information on operating systems that have been certified for use with the SuperServer 6018R-MT/6018R-MTR ([www.supermicro.com](http://www.supermicro.com)).

In addition to the serverboard and chassis, various hardware components have been included with the system, as listed below:

- Four 4-cm high-performance fans (FAN-0147L4)
- Two passive heat sinks (SNK-P0047PD)
- One air shroud (MCP-310-19015-0N)
- One PCI-Express 3.0 x8 riser card (RSC-RR1U-E8)
- SATA Accessories
  - One SATA backplane (BPN-SAS-815TQ)
  - Four 3.5" hard disk trays (MCP-220-00075-0B)
  - One SGPIO cable (CBL-CDAT-0661) and one SATA cable set (CBL-0186L)
- SuperServer 6018R-MT/6018R-MTR Quick Reference Guide

**Note:** For your system to work properly, please follow the links below to download all necessary drivers/utilities and the user's manual for your server.

- Supermicro product manuals: <http://www.supermicro.com/support/manuals/>
- Product drivers and utilities: <https://www.supermicro.com/wftp/driver>
- Product safety info: [http://www.supermicro.com/about/policies/safety\\_information.cfm](http://www.supermicro.com/about/policies/safety_information.cfm)

## 1-2 Serverboard Features

At the heart of the SuperServer 6018R-MT/6018R-MTR lies the X10DRL-i, a dual processor serverboard based on the Intel® PCH C612 chipset. Below are the main features of the X10DRL-i. See Figure 1-1 for a block diagram of the chipset.

### Processors

The X10DRL-i supports dual Intel® E5-2600 (v3/v4) Series processors (Socket R-LGA 2011). Please refer to the serverboard description pages on our website for a complete listing of supported processors ([www.supermicro.com](http://www.supermicro.com)).

### Memory

The X10DRL-i has eight DIMM slots that can support up to 1 TB of ECC LRDIMM (Load-Reduced DIMMs) or 512 GB of ECC RDIMM (registered DIMMs) DDR4-2400/2133/1866/1600 memory. DIMMs of the same size and speed should be used. See Chapter 5 for details.

### SATA

A SATA controller is integrated into the chipset to provide a 10-port Serial ATA subsystem (4x SATA 3.0 ports supported by the Intel SCU and 6x SATA 3.0 ports supported by the Intel PCH). The SATA drives are hot-swappable units.

### PCI Expansion Slots

The system supports one full-height, half-length PCI-Express 3.0 x8 card with the use of the installed RSC-RR1U-E8 riser card.

### I/O Ports

The color-coded I/O ports include a COM port, a VGA port, two USB 2.0 ports, two USB 3.0 ports, two Gb LAN (NIC) ports and a dedicated IPMI LAN port.

## 1-3 Server Chassis Features

The following is a general outline of the main features of the SC813MFTQ-400CB/R400CB chassis.

### System Power

When configured as a SuperServer 6018R-MT, the SC813MFTQ-400CB chassis includes a single 440/480W power supply (p/n PWS-441P-1H). When configured as a SuperServer 6018R-MTR, the SC813MFTQ-R400CB chassis includes a redundant 400W power supply (p/n PWS-406P-1R).

### SATA Subsystem

For the 6018R-MT/6018R-MTR, the SC813MFTQ-400CB/R400CB chassis was designed to support four hot-swappable SATA hard drives.

### Control Panel

The SC813MFTQ-400CB/R400CB's control panel provides important system monitoring and control information. LEDs indicate power on, network activity, hard disk drive activity and system overheat conditions. The control panel also includes a main power button and a system reset button.

### Cooling System

The SC813MFTQ-400CB/R400CB chassis has an innovative cooling design that features four 4-cm high-performance system cooling fans and an air shroud. Each of these fans plug into a chassis fan header on the serverboard. An air shroud channels the airflow generated by the fans to efficiently cool the processor area of the system. Fan speed is controlled by IPMI.

**Figure 1-1. Intel C612 Chipset:  
System Block Diagram**

**Note:** This is a general block diagram. Please see Chapter 5 for details.

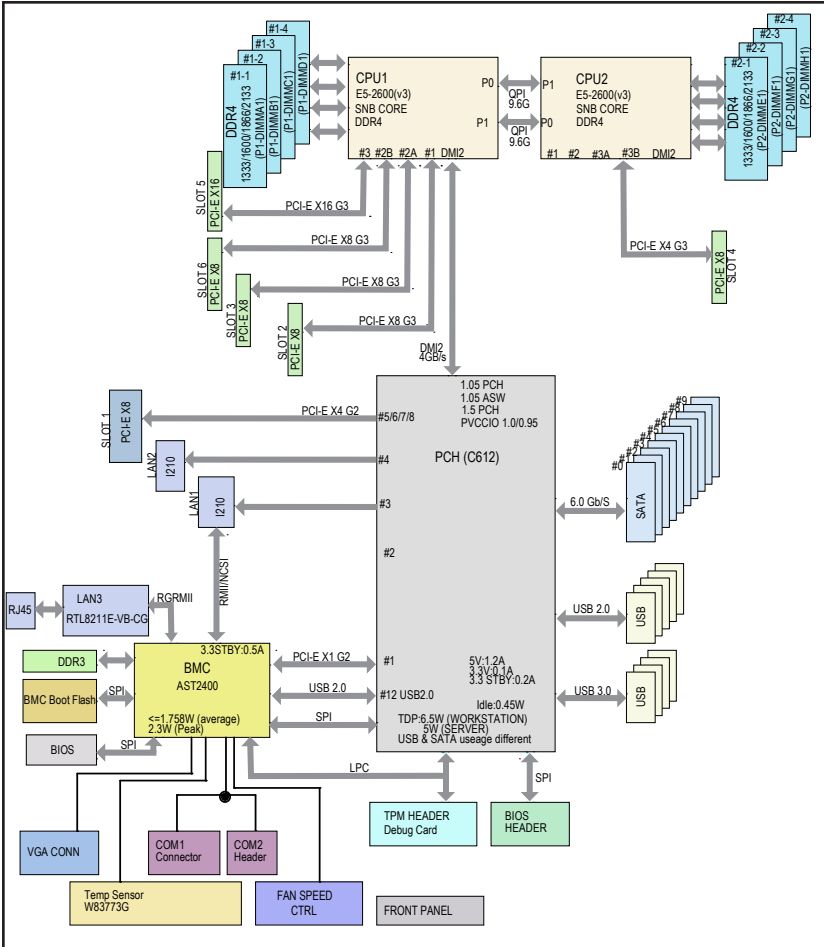

## 1-4 Contacting Supermicro

### Headquarters

Address: Super Micro Computer, Inc.  
980 Rock Ave.  
San Jose, CA 95131 U.S.A.

Tel: +1 (408) 503-8000

Fax: +1 (408) 503-8008

Email: [marketing@supermicro.com](mailto:marketing@supermicro.com) (General Information)  
[support@supermicro.com](mailto:support@supermicro.com) (Technical Support)

Web Site: [www.supermicro.com](http://www.supermicro.com)

### Europe

Address: Super Micro Computer B.V.  
Het Sterrenbeeld 28, 5215 ML  
's-Hertogenbosch, The Netherlands

Tel: +31 (0) 73-6400390

Fax: +31 (0) 73-6416525

Email: [sales@supermicro.nl](mailto:sales@supermicro.nl) (General Information)  
[support@supermicro.nl](mailto:support@supermicro.nl) (Technical Support)  
[rma@supermicro.nl](mailto:rma@supermicro.nl) (Customer Support)

Web Site: [www.supermicro.nl](http://www.supermicro.nl)

### Asia-Pacific

Address: Super Micro Computer, Inc.  
3F, No. 150, Jian 1st Rd.  
Zhonghe Dist., New Taipei City 235  
Taiwan (R.O.C)

Tel: +886-(2) 8226-3990

Fax: +886-(2) 8226-3992

Email: [support@supermicro.com.tw](mailto:support@supermicro.com.tw)

Web Site: [www.supermicro.com.tw](http://www.supermicro.com.tw)

# Notes



## Chapter 2

# Server Installation

### 2-1 Overview

This chapter provides a quick setup checklist to get your SuperServer 6018R-MT/6018R-MTR up and running. Following the steps in the order given should enable you to have the system operational within a minimal amount of time. This quick setup assumes that your system has come to you with the processor and memory preinstalled. If your system is not already fully integrated with a serverboard, processor, system memory etc., please turn to the chapter or section noted in each step for details on installing specific components.

### 2-2 Unpacking the System

You should inspect the box the server was shipped in and note if it was damaged in any way. If the server itself shows damage, you should file a damage claim with the carrier who delivered it.

Decide on a suitable location for the rack unit that will hold the server. It should be situated in a clean, dust-free area that is well ventilated. Avoid areas where heat, electrical noise and electromagnetic fields are generated. You will also need it placed near a grounded power outlet. Read the Rack and Server Precautions in the next section.

### 2-3 Preparing for Setup

The box the SuperServer 6018R-MT/6018R-MTR was shipped in should include two sets of rail assemblies, six rail mounting brackets and the mounting screws you will need to install the system into the rack. Follow the steps in the order given to complete the installation process in a minimal amount of time. Please read this section in its entirety before you begin the installation procedure outlined in the sections that follow.

#### Choosing a Setup Location

- Leave enough clearance in front of the rack to enable you to open the front door completely (~25 inches) and approximately 30 inches of clearance in the back of the rack to allow for sufficient airflow and ease in servicing. This product is for

installation only in a Restricted Access Location (dedicated equipment rooms, service closets and the like).

- This product is not suitable for use with visual display work place devices according to §2 of the German Ordinance for Work with Visual Display Units.

## 2-4 Warnings and Precautions

### Rack Precautions

- Ensure that the leveling jacks on the bottom of the rack are fully extended to the floor with the full weight of the rack resting on them.
- In single rack installation, stabilizers should be attached to the rack. In multiple rack installations, the racks should be coupled together.
- Always make sure the rack is stable before extending a component from the rack.
- You should extend only one component at a time - extending two or more simultaneously may cause the rack to become unstable.

### Server Precautions

- Review the electrical and general safety precautions in Chapter 4.
- Determine the placement of each component in the rack *before* you install the rails.
- Install the heaviest server components on the bottom of the rack first, and then work up.
- Use a regulating uninterruptible power supply (UPS) to protect the server from power surges, voltage spikes and to keep your system operating in case of a power failure.
- Allow the hot plug SATA drives and power supply modules to cool before touching them.
- Always keep the rack's front door and all panels and components on the servers closed when not servicing to maintain proper cooling.

## **Rack Mounting Considerations**

### ***Ambient Operating Temperature***

If installed in a closed or multi-unit rack assembly, the ambient operating temperature of the rack environment may be greater than the ambient temperature of the room. Therefore, consideration should be given to installing the equipment in an environment compatible with the manufacturer's maximum rated ambient temperature (T<sub>mra</sub>).

### ***Reduced Airflow***

Equipment should be mounted into a rack so that the amount of airflow required for safe operation is not compromised.

### ***Mechanical Loading***

Equipment should be mounted into a rack so that a hazardous condition does not arise due to uneven mechanical loading.

### ***Circuit Overloading***

Consideration should be given to the connection of the equipment to the power supply circuitry and the effect that any possible overloading of circuits might have on overcurrent protection and power supply wiring. Appropriate consideration of equipment nameplate ratings should be used when addressing this concern.

### ***Reliable Ground***

A reliable ground must be maintained at all times. To ensure this, the rack itself should be grounded. Particular attention should be given to power supply connections other than the direct connections to the branch circuit (i.e. the use of power strips, etc.).

## 2-5 Installing the System into a Rack

This section provides information on installing the SuperServer 6018R-MT/6018R-MTR into a rack unit with the rack rails provided. If the server has already been mounted into a rack, you can skip ahead to Sections 2-5 and 2-6.

There are a variety of rack units on the market, which may mean the assembly procedure will differ slightly. You should also refer to the installation instructions that came with the rack unit you are using.

### Identifying the Sections of the Rack Rails

You may have received rack rail hardware with the server. (Two front inner rails should already be attached to the chassis.) This hardware consists of two rear inner rails that secure to the chassis, one on each side just behind the preinstalled front inner rails. Note that these two rails are left/right specific.

### Installing the Rear Inner Rails

First, locate the right rear inner rail (the rail that will be used on the right side of the chassis when you face the front of the chassis). Align the two square holes on the rail against the hooks on the right side of the chassis. Securely attach the rail to the chassis with M4 flat head screws. Repeat these steps to install the left rear inner rail to the left side of the chassis (see Figure 2-1). You will also need to attach the rail brackets when installing into a telco rack.

**Locking Tabs:** Both chassis rails have a locking tab, which serves two functions. The first is to lock the server into place when installed and pushed fully into the rack, which is its normal position. Secondly, these tabs also lock the server in place when fully extended from the rack. This prevents the server from coming completely out of the rack when you pull it out for servicing.

Figure 2-1. Installing Rear Inner Chassis Rails

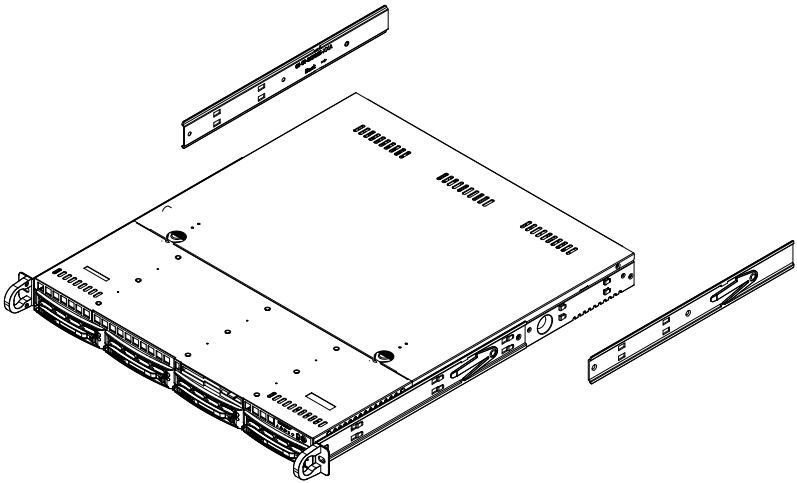

## Installing the Rack Rails

Determine where you want to place the SuperServer 6018R-MT/6018R-MTR in the rack ([see Rack and Server Precautions in Section 2-4](#)). Position the chassis rail guides at the desired location in the rack, keeping the sliding rail guide facing the inside of the rack. Screw the assembly securely to the rack using the brackets provided. Attach the other assembly to the other side of the rack, making sure that both are at the exact same height and with the rail guides facing inward.



**Warning!** To prevent bodily injury when mounting or servicing this unit in a rack, you must take special precautions to ensure that the system remains stable. The following guidelines are provided to ensure your safety:

- This unit should be mounted at the bottom of the rack if it is the only unit in the rack.
- When mounting this unit in a partially filled rack, load the rack from the bottom to the top with the heaviest component at the bottom of the rack.
- If the rack is provided with stabilizing devices, install the stabilizers before mounting or servicing the unit in the rack.

## Installing the Server into the Rack

You should now have rails attached to both the chassis and the rack unit. The next step is to install the server into the rack. Do this by lining up the rear of the chassis rails with the front of the rack rails. Slide the chassis rails into the rack rails, keeping the pressure even on both sides (you may have to depress the locking tabs when inserting). See Figure 2-2.

When the server has been pushed completely into the rack, you should hear the locking tabs "click".

**Figure 2-2. Installing the Server into a Rack**

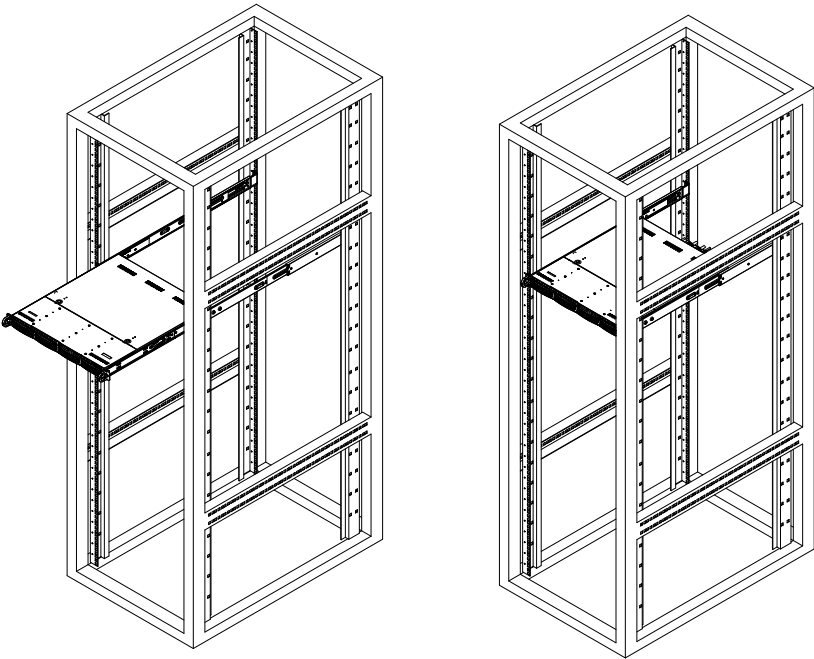

**Note:** figures are for illustrative purposes only. Always install servers to the bottom of a rack first.



**Warning:** do not pick up the server with the front handles. They are designed to pull the system from a rack only.



Slide rail mounted equipment is not to be used as a shelf or a work space.

## Installing the Server into a Telco Rack

To install the SuperServer 6018R-MT/6018R-MTR into a Telco type rack, use two L-shaped brackets on either side of the chassis (four total). First, determine how far the server will extend out the front of the rack. Larger chassis should be positioned to balance the weight between front and back. If a bezel is included on your server, remove it. Then attach the two front brackets to each side of the chassis, then the two rear brackets positioned with just enough space to accommodate the width of the rack. Finish by sliding the chassis into the rack and tightening the brackets to the rack.

**Figure 2-3. Installing the Server into a Telco Rack**

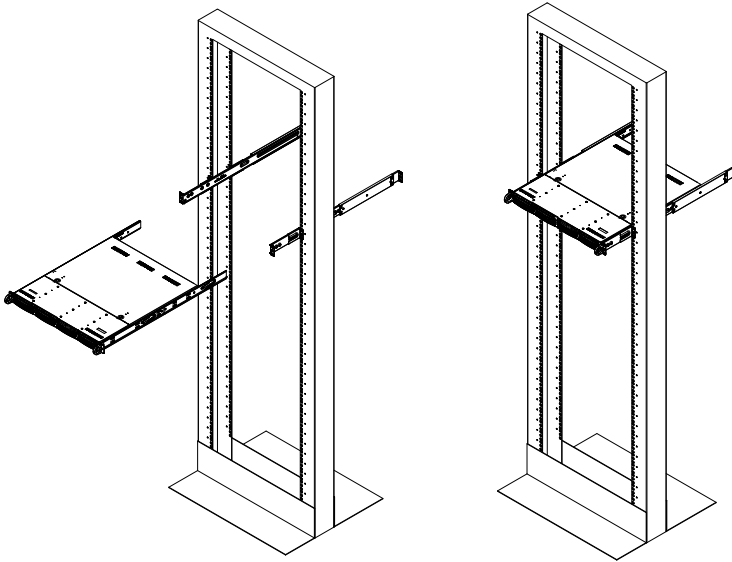

**Note:** figures are for illustrative purposes only. Always install servers to the bottom of a rack first.



Stability hazard. The rack stabilizing mechanism must be in place, or the rack must be bolted to the floor before you slide the unit out for servicing. Failure to stabilize the rack can cause the rack to tip over.

## Notes



## Chapter 3

# System Interface

### 3-1 Overview

There are several LEDs on the control panel as well as others on the hard drive carriers to keep you constantly informed of the overall status of the system as well as the activity and health of specific components. There are also two buttons on the chassis control panel.

This chapter explains the meanings of all LED indicators and any appropriate response you may need to take.

### 3-2 Control Panel Buttons

There are two push-buttons located on the front of the chassis: a reset button and a power on/off button.

RESET



#### Reset

The reset button reboots the system.



#### Power

This is the main power button, which is used to apply or turn off the main system power. Turning off system power with this button removes the main power but keeps standby power supplied to the system.

### 3-3 Control Panel LEDs

The control panel located on the front of the SC813MFTQ-400CB/R400CB chassis has five LEDs. These LEDs provide you with critical information related to different parts of the system. This section explains what each LED indicates when illuminated and any corrective action you may need to take.



#### Information LED

This LED will be solid blue when the UID function has been activated. When this LED flashes red, it indicates a fan failure. When red continuously it indicates an overheat condition, which may be caused by cables obstructing the airflow in the system or the ambient room temperature being too warm. Check the routing of the cables and make sure all fans are present and operating normally. You should also check to make sure that the chassis covers are installed. Finally, verify that the heatsinks are installed properly (see Chapter 5). This LED will remain flashing or on as long as the indicated condition exists.



#### NIC2

Indicates network activity on LAN2 when flashing.



#### NIC1

Indicates network activity on LAN1 when flashing.



#### HDD

Channel activity for all HDDs. This light indicates hard drive activity on the 6018R-MT/6018R-MTR when flashing.



## Power

Indicates power is being supplied to the system's power supply units. This LED should normally be illuminated when the system is operating.

### 3-4 Hard Drive Carrier LEDs

Each drive carrier has two LEDs.

- **Green:** When illuminated, the green LED on the drive carrier indicates drive activity. A connection to the backplane enables this LED to blink on and off when that particular drive is being accessed.
- **Red:** The red LED to indicate a drive failure. If one of the drives fails, you should be notified by your system management software. Please refer to Chapter 6 for instructions on replacing failed drives.

# Notes

## Chapter 4

# Standardized Warning Statements for AC Systems

### 4-1 About Standardized Warning Statements

The following statements are industry standard warnings, provided to warn the user of situations which have the potential for bodily injury. Should you have questions or experience difficulty, contact Supermicro's Technical Support department for assistance. Only certified technicians should attempt to install or configure components.

Read this appendix in its entirety before installing or configuring components in the Supermicro chassis.

These warnings may also be found on our web site at [http://www.supermicro.com/about/policies/safety\\_information.cfm](http://www.supermicro.com/about/policies/safety_information.cfm).

#### Warning Definition



#### Warning!

This warning symbol means danger. You are in a situation that could cause bodily injury. Before you work on any equipment, be aware of the hazards involved with electrical circuitry and be familiar with standard practices for preventing accidents.

#### 警告の定義

この警告サインは危険を意味します。

人身事故につながる可能性がありますので、いずれの機器でも動作させる前に、電気回路に含まれる危険性に注意して、標準的な事故防止策に精通して下さい。

此警告符号代表危險。

您正处于可能受到严重伤害的工作环境中。在您使用设备开始工作之前，必须充分意识到触电的危险，并熟练掌握防止事故发生的标准工作程序。请根据每项警告结尾的声明号码找到此设备的安全性警告说明的翻译文本。

此警告符號代表危險。

您目前所處的工作環境可能讓您受傷。您使用任何設備之前，請注意觸電的危險，並且要熟悉預防事故發生的標準工作程序。請依照每一注意事項後的號碼找到相關的翻譯說明內容。

## Warnung

### WICHTIGE SICHERHEITSHINWEISE

Dieses Warnsymbol bedeutet Gefahr. Sie befinden sich in einer Situation, die zu Verletzungen führen kann. Machen Sie sich vor der Arbeit mit Geräten mit den Gefahren elektrischer Schaltungen und den üblichen Verfahren zur Vorbeugung vor Unfällen vertraut. Suchen Sie mit der am Ende jeder Warnung angegebenen Anweisungsnummer nach der jeweiligen Übersetzung in den übersetzten Sicherheitshinweisen, die zusammen mit diesem Gerät ausgeliefert wurden.

BEWAHREN SIE DIESE HINWEISE GUT AUF.

### INSTRUCCIONES IMPORTANTES DE SEGURIDAD

Este símbolo de aviso indica peligro. Existe riesgo para su integridad física. Antes de manipular cualquier equipo, considere los riesgos de la corriente eléctrica y familiarícese con los procedimientos estándar de prevención de accidentes. Al final de cada advertencia encontrará el número que le ayudará a encontrar el texto traducido en el apartado de traducciones que acompaña a este dispositivo.

GUARDE ESTAS INSTRUCCIONES.

### IMPORTANTES INFORMATIONS DE SÉCURITÉ

Ce symbole d'avertissement indique un danger. Vous vous trouvez dans une situation pouvant entraîner des blessures ou des dommages corporels. Avant de travailler sur un équipement, soyez conscient des dangers liés aux circuits électriques et familiarisez-vous avec les procédures couramment utilisées pour éviter les accidents. Pour prendre connaissance des traductions des avertissements figurant dans les consignes de sécurité traduites qui accompagnent cet appareil, référez-vous au numéro de l'instruction situé à la fin de chaque avertissement.

CONSERVEZ CES INFORMATIONS.

### תקנון הצהרות אזהרה

הצהרות הבאות הן אזהרות על פי תקני התעשייה, על מנת להזהיר את המשתמש מפני חבלה פיזית אפשרית. במידה ויש שאלות או היתקלות בבעיה כלשהי, יש ליצור קשר עם מחלקת תמיכה טכנית של סופרמיקרו. טכנאים מוסמכים בלבד רשאים להתקין או להגדיר את הרכיבים. יש לקרוא את הנספח במלואו לפני התקנת או הגדרת הרכיבים במאזני סופרמיקרו.

أَكْ فِ حَالَةٍ وَكِي أَي تَتَسَبَّبُ فِ إِصَابَةِ جَسَدٍ هَذَا الزَّهْرُ عَ خَطَرَ! تَحْذَرُ .  
قَبْلَ أَي تَعْوَلُ عَلَى أَي هَعْدَاتٍ، كِي عَلَى عِلْنِ بِالوَخَاظِرِ الِ أُجُودَةِ عِي الذَّوَاتِرِ  
الكَهْزِبَائِيَّةِ  
وَكَي عَلَى دَرَاةٍ بِالْوَوَارِسَاتِ الْمَقَائِيَّةِ لَوْ عَ وَقَعَ أَي حَادِثٍ  
اسْتَعْمَدَ رَقْنَ الْبِ إِلَى الْوَصْصِ فَ هَآءُ كُلُّ تَحْذَرٍ لِلْعَثْرِ تَرْجُوتَهَا

안전을 위한 주의사항

경고!

이 경고 기호는 위험이 있음을 알려 줍니다. 작업자의 신체에 부상을 야기 할 수 있는 상태에 있게 됩니다. 모든 장비에 대한 작업을 수행하기 전에 전기회로와 관련된 위험요소들을 확인하시고 사전에 사고를 방지할 수 있도록 표준 작업절차를 준수해 주시기 바랍니다.

해당 번역문을 찾기 위해 각 경고의 마지막 부분에 제공된 경고문 번호를 참조하십시오

#### BELANGRIJKE VEILIGHEIDSINSTRUCTIES

Dit waarschuwings symbool betekent gevaar. U verkeert in een situatie die lichamelijk letsel kan veroorzaken. Voordat u aan enige apparatuur gaat werken, dient u zich bewust te zijn van de bij een elektrische installatie betrokken risico's en dient u op de hoogte te zijn van de standaard procedures om ongelukken te voorkomen. Gebruik de nummers aan het eind van elke waarschuwing om deze te herleiden naar de desbetreffende locatie.

#### BEWAAR DEZE INSTRUCTIES

## Installation Instructions



### Warning!

Read the installation instructions before connecting the system to the power source.

設置手順書

システムを電源に接続する前に、設置手順書をお読み下さい。

警告

将此系统连接电源前,请先阅读安装说明。

警告

將系統與電源連接前·請先閱讀安裝說明。

Warnung

Vor dem Anschließen des Systems an die Stromquelle die Installationsanweisungen lesen.

¡Advertencia!

Lea las instrucciones de instalación antes de conectar el sistema a la red de alimentación.

Attention

Avant de brancher le système sur la source d'alimentation, consulter les directives d'installation.

יש לקרוא את הוראות התקנה לפני חיבור המערכת למקור מתח.

اقر إرشادات التركيب قبل توصيل النظام إلى مصدر للطاقة

시스템을 전원에 연결하기 전에 설치 안내를 읽어주시십시오.

Waarschuwing

Raadpleeg de installatie-instructies voordat u het systeem op de voedingsbron aansluit.



## Circuit Breaker



### Warning!

This product relies on the building's installation for short-circuit (overcurrent) protection. Ensure that the protective device is rated not greater than: 250 V, 20 A.

サーキット・ブレーカー

この製品は、短絡(過電流)保護装置がある建物での設置を前提としています。

保護装置の定格が250 V、20 Aを超えないことを確認下さい。

### 警告

此产品的短路(过载电流)保护由建筑物的供电系统提供,确保短路保护设备的额定电流不大于250V,20A。

### 警告

此產品的短路(過載電流)保護由建築物的供電系統提供,確保短路保護設備的額定電流不大於250V,20A。

### Warnung

Dieses Produkt ist darauf angewiesen, dass im Gebäude ein Kurzschluss- bzw. Überstromschutz installiert ist. Stellen Sie sicher, dass der Nennwert der Schutzvorrichtung nicht mehr als: 250 V, 20 A beträgt.

### ¡Advertencia!

Este equipo utiliza el sistema de protección contra cortocircuitos (o sobrecorrientes) del edificio. Asegúrese de que el dispositivo de protección no sea superior a: 250 V, 20 A.

### Attention

Pour ce qui est de la protection contre les courts-circuits (surtension), ce produit dépend de l'installation électrique du local. Vérifiez que le courant nominal du dispositif de protection n'est pas supérieur à :250 V, 20 A.

מוצר זה מסתמך על הגנה המותקנת במבנים למניעת קצר חשמלי. יש לוודא כי המכשיר המוגן מפני הקצר החשמלי הוא לא יותר מ-250VDC, 20A

هذا المنتج يعتمد على معدات الحماية مه الدوائر القصيرة التي تم تثبيتها في  
المبنى  
تأكد من أن تقييم الجهاز الوقائي ليس أكثر من : 20A, 250V

경고!

이 제품은 전원의 단락(과전류)방지에 대해서 전적으로 건물의 관련 설비에 의존합니다. 보호장치의 정격이 반드시 250V(볼트), 20A(암페어)를 초과하지 않도록 해야 합니다.

Waarschuwing

Dit product is afhankelijk van de kortsluitbeveiliging (overspanning) van uw elektrische installatie. Controleer of het beveiligde apparaat niet groter gedimensioneerd is dan 250V, 20A.

## Power Disconnection Warning



### Warning!

The system must be disconnected from all sources of power and the power cord removed from the power supply module(s) before accessing the chassis interior to install or remove system components.

### 電源切斷の警告

システムコンポーネントの取り付けまたは取り外しのために、シャーシ内部にアクセスするには、

システムの電源はすべてのソースから切斷され、電源コードは電源モジュールから取り外す必要があります。

警告

在你打开机箱并安装或移除内部器件前,必须将系统完全断电,并移除电源线。

警告

在您打開機殼安裝或移除內部元件前·必須將系統完全斷電·並移除電源線。

Warnung

Das System muss von allen Quellen der Energie und vom Netzanschlusskabel getrennt sein, das von den Spg.Versorgungsteilmodulen entfernt wird, bevor es auf den Chassisinnenraum zurückgreift, um Systemsbestandteile anzubringen oder zu entfernen.

¡Advertencia!

El sistema debe ser disconnected de todas las fuentes de energía y del cable eléctrico quitado de los módulos de fuente de alimentación antes de tener acceso el interior del chasis para instalar o para quitar componentes de sistema.

Attention

Le système doit être débranché de toutes les sources de puissance ainsi que de son cordon d'alimentation secteur avant d'accéder à l'intérieur du châssis pour installer ou enlever des composants de système.

אזהרה מפני ניתוק חשמלי

!אזהרה

יש לנתק את המערכת מכל מקורות החשמל ויש להסיר את כבל החשמלי מהספק לפני גישה לחלק הפנימי של המארז לצורך התקנת או הסרת רכיבים.

يجب فصل انظاؤ من جميع مصادر انطاقت وإزانت سهك انكهرياء من وحدة امداد

انطاقت قيم

انصلل إني اماناطق انداخييت نههيكم نتثييج أو إزانت مكنناث الجهاز

경고!

시스템에 부품들을 장착하거나 제거하기 위해서는 새시 내부에 접근하기 전에 반드시 전원 공급장치로부터 연결되어있는 모든 전원과 전기코드를 분리해주어야 합니다.

Waarschuwing

Voordat u toegang neemt tot het binnenwerk van de behuizing voor het installeren of verwijderen van systeem onderdelen, dient u alle spanningsbronnen en alle stroomkabels aangesloten op de voeding(en) van de behuizing te verwijderen

## Equipment Installation



### Warning!

Only trained and qualified personnel should be allowed to install, replace, or service this equipment.

### 機器の設置

トレーニングを受け認定された人だけがこの装置の設置、交換、またはサービスを許可されています。

### 警告

只有经过培训且具有资格的人员才能进行此设备的安装、更换和维修。

### 警告

只有經過受訓且具資格人員才可安裝、更換與維修此設備。

### Warnung

Das Installieren, Ersetzen oder Bedienen dieser Ausrüstung sollte nur geschultem, qualifiziertem Personal gestattet werden.

### ¡Advertencia!

Solamente el personal calificado debe instalar, reemplazar o utilizar este equipo.

### Attention

Il est vivement recommandé de confier l'installation, le remplacement et la maintenance de ces équipements à des personnels qualifiés et expérimentés.

### אזהרה!

צוות מוסמך בלבד רשאי להתקין, להחליף את הציוד או לתת שירות עבור הציוד.

والمدربيه لتتركيب واستبدال أو خدمة هذا الجهاز يجب أن يسمح فقط للموظفيه المؤهليه

### 경고!

훈련을 받고 공인된 기술자만이 이 장비의 설치, 교체 또는 서비스를 수행할 수 있습니다.

## Waarschuwing

Deze apparatuur mag alleen worden geïnstalleerd, vervangen of hersteld door geschoold en gekwalificeerd personeel.

## Restricted Area



### Warning!

This unit is intended for installation in restricted access areas. A restricted access area can be accessed only through the use of a special tool, lock and key, or other means of security. (This warning does not apply to workstations).

## アクセス制限区域

このユニットは、アクセス制限区域に設置されることを想定しています。

アクセス制限区域は、特別なツール、鍵と錠前、その他のセキュリティの手段を用いてのみ出入りが可能です。

## 警告

此部件应安装在限制进出的场所。限制进出的场所指只能通过使用特殊工具、锁和钥匙或其它安全手段进出的场所。

## 警告

此装置僅限安裝於進出管制區域。進出管制區域係指僅能以特殊工具、鎖頭及鑰匙或其他安全方式才能進入的區域。

## Warnung

Diese Einheit ist zur Installation in Bereichen mit beschränktem Zutritt vorgesehen. Der Zutritt zu derartigen Bereichen ist nur mit einem Spezialwerkzeug, Schloss und Schlüssel oder einer sonstigen Sicherheitsvorkehrung möglich.

## ¡Advertencia!

Esta unidad ha sido diseñada para instalación en áreas de acceso restringido. Sólo puede obtenerse acceso a una de estas áreas mediante la utilización de una herramienta especial, cerradura con llave u otro medio de seguridad.

## Attention

Cet appareil doit être installée dans des zones d'accès réservés. L'accès à une zone d'accès réservé n'est possible qu'en utilisant un outil spécial, un mécanisme de verrouillage et une clé, ou tout autre moyen de sécurité.

אזור עם גישה מוגבלת

אזהרה!

יש להתקין את היחידה באזורים שיש בהם הגבלת גישה. הגישה ניתנת בעזרת 'כלי אבטחה בלבד' (מפתח, מנעול וכד.).

تخصيص هذه انحدثة نترك بُها ف مناطق محظورة تم .  
،ممكن اننصل إن منطقت محظورة فقط من خلال استخداو أداة خاصت  
أو أ وس هُت أخري نلالأما ققم ومفتاح

경고!

이 장치는 접근이 제한된 구역에 설치하도록 되어 있습니다. 특수 도구, 잠금 장치 및 키, 또는 기타 보안 수단을 통해서만 접근 제한 구역에 들어갈 수 있습니다.

Waarschuwing

Dit apparaat is bedoeld voor installatie in gebieden met een beperkte toegang. Toegang tot dergelijke gebieden kunnen alleen verkregen worden door gebruik te maken van speciaal gereedschap, slot en sleutel of andere veiligheidsmaatregelen.

## Battery Handling



### Warning!

There is the danger of explosion if the battery is replaced incorrectly. Replace the battery only with the same or equivalent type recommended by the manufacturer. Dispose of used batteries according to the manufacturer's instructions

電池の取り扱い

電池交換が正しく行われなかった場合、破裂の危険性があります。交換する電池はメーカーが推奨する型、または同等のものを使用下さい。使用済電池は製造元の指示に従って処分して下さい。

警告

電池更換不當會有爆炸危險。請只使用同類電池或製造商推薦的功能相當的電池更換原有電池。請按製造商的說明處理廢舊電池。

警告

電池更換不當會有爆炸危險。請使用製造商建議之相同或功能相當的電池更換原有電池。請按照製造商的說明指示處理廢棄舊電池。

### Warnung

Bei Einsetzen einer falschen Batterie besteht Explosionsgefahr. Ersetzen Sie die Batterie nur durch den gleichen oder vom Hersteller empfohlenen Batterietyp. Entsorgen Sie die benutzten Batterien nach den Anweisungen des Herstellers.

### Attention

Danger d'explosion si la pile n'est pas remplacée correctement. Ne la remplacer que par une pile de type semblable ou équivalent, recommandée par le fabricant. Jeter les piles usagées conformément aux instructions du fabricant.

### ¡Advertencia!

Existe peligro de explosión si la batería se reemplaza de manera incorrecta. Reemplazar la batería exclusivamente con el mismo tipo o el equivalente recomendado por el fabricante. Desechar las baterías gastadas según las instrucciones del fabricante.

### אזהרה!

קיימת סכנת פיצוץ של הסוללה במידה והוחלפה בדרך לא תקינה. יש להחליף את הסוללה בסוג התואם מחברת יצרן מומלצת. סילוק הסוללות המשומשות יש לבצע לפי הוראות היצרן.

هناك خطر من انفجار في حالة اسبدال البطارية بطريقة غير صحيحة فاعلil  
اسبدال البطارية  
فقط بنفس النوع أو ما يعادلها مما أوصت به الشركة المصنعة  
جخلص من البطاريات المسحمة وفقا لعمليات الشركة الصانعة

### 경고!

배터리가 올바르게 교체되지 않으면 폭발의 위험이 있습니다. 기존 배터리와 동일하거나 제조사에서 권장하는 동등한 종류의 배터리로만 교체해야 합니다. 제조사의 안내에 따라 사용된 배터리를 처리하여 주십시오.

### Waarschuwing

Er is ontploffingsgevaar indien de batterij verkeerd vervangen wordt. Vervang de batterij slechts met hetzelfde of een equivalent type die door de fabrikant aanbevolen wordt. Gebruikte batterijen dienen overeenkomstig fabrieksvoorschriften afgevoerd te worden.

## Redundant Power Supplies



### Warning!

This unit might have more than one power supply connection. All connections must be removed to de-energize the unit.

#### 冗長電源装置

このユニットは複数の電源装置が接続されている場合があります。  
ユニットの電源を切るためには、すべての接続を取り外さなければなりません。

#### 警告

此部件连接的电源可能不止一个·必须将所有电源断开才能停止给该部件供电。

#### 警告

此装置连接的电源可能不只一个·必须切断所有电源才能停止对该装置的供电。

#### Warnung

Dieses Gerät kann mehr als eine Stromzufuhr haben. Um sicherzustellen, dass der Einheit kein Strom zugeführt wird, müssen alle Verbindungen entfernt werden.

#### ¡Advertencia!

Puede que esta unidad tenga más de una conexión para fuentes de alimentación. Para cortar por completo el suministro de energía, deben desconectarse todas las conexiones.

#### Attention

Cette unité peut avoir plus d'une connexion d'alimentation. Pour supprimer toute tension et tout courant électrique de l'unité, toutes les connexions d'alimentation doivent être débranchées.

אם קיים יותר מספק אחד

אזהרה!

ליחידה יש יותר מחיבור אחד של ספק. יש להסיר את כל החיבורים על מנת לרוקן את היחידה.



قد يكون لهذا الجهاز عدة اتصالات بوحدات امداد الطاقة .  
يجب إزالة كافة الاتصالات لغسل الوحدة عن الكهرباء

경고!

이 장치에는 한 개 이상의 전원 공급 단자가 연결되어 있을 수 있습니다. 이 장치에 전원을 차단하기 위해서는 모든 연결 단자를 제거해야만 합니다.

Waarschuwing

Deze eenheid kan meer dan één stroomtoevoeraansluiting bevatten. Alle aansluitingen dienen verwijderd te worden om het apparaat stroomloos te maken.

### Backplane Voltage



#### Warning!

Hazardous voltage or energy is present on the backplane when the system is operating. Use caution when servicing.

バックプレーンの電圧

システムの稼働中は危険な電圧または電力が、バックプレーン上にかかっています。

修理する際にはご注意ください。

警告

当系统正在进行时·背板上有很危险的电压或能量·进行维修时务必小心。

警告

當系統正在進行時·背板上有危險的電壓或能量·進行維修時務必小心。

Warnung

Wenn das System in Betrieb ist, treten auf der Rückwandplatine gefährliche Spannungen oder Energien auf. Vorsicht bei der Wartung.

¡Advertencia!

Cuando el sistema está en funcionamiento, el voltaje del plano trasero es peligroso. Tenga cuidado cuando lo revise.

Attention

Lorsque le système est en fonctionnement, des tensions électriques circulent sur le fond de panier. Prendre des précautions lors de la maintenance.

מתח בפנל האחורי

אזהרה!

קיימת סכנת מתח בפנל האחורי בזמן תפעול המערכת. יש להיזהר במהלך העבודה.

هناك خطر من التيار الكهربائي أو الطاقة المخزنة على اللوحة عندما يكن النظام يعمل كه حذرا عند خدمة هذا الجهاز

경고!

시스템이 동작 중일 때 후면판 (Backplane)에는 위험한 전압이나 에너지가 발생할 수 있습니다. 서비스 작업 시 주의하십시오.

Waarschuwing

Een gevaarlijke spanning of energie is aanwezig op de backplane wanneer het systeem in gebruik is. Voorzichtigheid is geboden tijdens het onderhoud.

## Comply with Local and National Electrical Codes



### Warning!

Installation of the equipment must comply with local and national electrical codes.

地方および国の電気規格に準拠

機器の取り付けはその地方および国の電気規格に準拠する必要があります。

警告

设备安装必须符合本地与本国电气法规。

警告

設備安裝必須符合本地與本國電氣法規。

Warnung

Die Installation der Geräte muss den Sicherheitsstandards entsprechen.

¡Advertencia!

La instalación del equipo debe cumplir con las normas de electricidad locales y nacionales.

Attention

L'équipement doit être installé conformément aux normes électriques nationales et locales.

תיאום חוקי החשמל הארצי

אזהרה!

התקנת הציוד חייבת להיות תואמת לחוקי החשמל המקומיים והארציים.

تركيب المعدات الكهربائية يجب أن يمتثل للقوايه المحلية والطبية المتعلقة

بالكهرباء

경고!

현 지역 및 국가의 전기 규정에 따라 장비를 설치해야 합니다.

Waarschuwing

Bij installatie van de apparatuur moet worden voldaan aan de lokale en nationale elektriciteitsvoorschriften.

**Product Disposal**



**Warning!**

Ultimate disposal of this product should be handled according to all national laws and regulations.

製品の廃棄

この製品を廃棄処分する場合、国の関係する全ての法律・条例に従い処理する必要があります。

警告

本产品的废弃处理应根据所有国家的法律和规章进行。

警告

本產品的廢棄處理應根據所有國家的法律和規章進行。

Warnung

Die Entsorgung dieses Produkts sollte gemäß allen Bestimmungen und Gesetzen des Landes erfolgen.

¡Advertencia!

Al deshacerse por completo de este producto debe seguir todas las leyes y reglamentos nacionales.

## Attention

La mise au rebut ou le recyclage de ce produit sont généralement soumis à des lois et/ou directives de respect de l'environnement. Renseignez-vous auprès de l'organisme compétent.

סילוק המוצר

!אזהרה!

סילוק סופי של מוצר זה חייב להיות בהתאם להנחיות וחוקי המדינה.

التخلص النهائي من هذا المنتج ينبغي التعامل معه وفقا لجميع القوانين واللوائح الوطنية عند

## 경고!

이 제품은 해당 국가의 관련 법규 및 규정에 따라 폐기되어야 합니다.

## Waarschuwing

De uiteindelijke verwijdering van dit product dient te geschieden in overeenstemming met alle nationale wetten en reglementen.

## Hot Swap Fan Warning



## Warning!



Hazardous moving parts. Keep away from moving fan blades. The fans might still be turning when you remove the fan assembly from the chassis. Keep fingers, screwdrivers, and other objects away from the openings in the fan assembly's housing.

## ファン・ホットスワップの警告

警告!回転部品に注意。運転中は回転部(羽根)に触れないでください。シャーシから冷却ファン装置を取り外した際、ファンがまだ回転している可能性があります。ファンの開口部に、指、ドライバー、およびその他のものを近づけないで下さい。

## 警告!

警告! 危险的可移动性零件。请务必与转动的风扇叶片保持距离。当您从机架移除风扇装置, 风扇可能仍在转动。小心不要将手指、螺丝起子和其他物品太靠近风扇。

## 警告

危险的可移动性零件。请务必与转动的风扇叶片保持距离。当您从机架移除风扇装置, 风扇可能仍在转动。小心不要将手指、螺丝起子和其他物品太靠近风扇。

**Warnung**

Gefährlich Bewegende Teile. Von den bewegenden Lüfterblätter fern halten. Die Lüfter drehen sich u. U. noch, wenn die Lüfterbaugruppe aus dem Chassis genommen wird. Halten Sie Finger, Schraubendreher und andere Gegenstände von den Öffnungen des Lüftergehäuses entfernt.

**¡Advertencia!**

Riesgo de piezas móviles. Mantener alejado de las aspas del ventilador. Los ventiladores podran dar vuelta cuando usted quite el montaje del ventilador del chasis. Mandtenga los dedos, los destornilladores y todos los objetos lejos de las aberturas del ventilador

**Attention**

Pieces mobiles dangereuses. Se tenir a l'ecart des lames du ventilateur Il est possible que les ventilateurs soient toujours en rotation lorsque vous retirerez le bloc ventilateur du châssis. Prenez garde à ce que doigts, tournevis et autres objets soient éloignés du logement du bloc ventilateur.

**אזהרה!**

חלקים נעים מסוכנים. התרחק מלהבי המאוורר בפעולה כאשר מסירים את חלקי המאוורר מהמארז, יתכן והמאווררים עדיין עובדים. יש להרחיק למרחק בטוח את האצבעות וכלי עבודה שונים מהפתחים בתוך המאוורר

تحذير! أجزاء متحركة خطيرة. ابتعد عن شفرات المروحة المتحركة. من الممكن أن المراوح لا تزال تدور عند إزالة كتلة المروحة من الهيكل يجب إبقاء الأصابع ومفكات البراغي وغيرها من الأشياء بعيدا عن الفتحات في كتلة المروحة

**경고!**

움직이는 위험한 부품. 회전하는 송풍 날개에 접근하지 마세요. 채시로부터 팬 조립품을 제거할 때 팬은 여전히 회전하고 있을 수 있습니다. 팬 조립품 외관의 열려있는 부분들로부터 손가락 및 스크류드라이버, 다른 물체들이 가까이 하지 않도록 배치해 주십시오.

**Waarschuwing**

Gevaarlijk bewegende onderdelen. Houd voldoende afstand tot de bewegende ventilatorbladen. Het is mogelijk dat de ventilator nog draait tijdens het verwijderen van het ventilatorsamenstel uit het chassis. Houd uw vingers, schroevendraaiers en eventuele andere voorwerpen uit de buurt van de openingen in de ventilatorbehuizing.

## Power Cable and AC Adapter



### Warning!

**Warning!** When installing the product, use the provided or designated connection cables, power cables and AC. Using any other cables and adaptors could cause a malfunction or a fire. Electrical Appliance and Material Safety Law prohibits the use of UL or CSA -certified cables (that have UL/CSA shown on the code) for any other electrical devices than products designated by Supermicro only..

### 電源コードとACアダプター

製品を設置する場合、提供または指定および購入された接続ケーブル、電源コードとACアダプターを、該当する地域の条例や安全基準に適合するコードサイズやプラグと共に使用下さい。他のケーブルやアダプタを使用すると故障や火災の原因になることがあります。電気用品安全法は、ULまたはCSA認定のケーブル(UL/CSEマークがコードに表記)を Supermicroが指定する製品以外に使用することを禁止しています。

### 警告

安裝此產品時,請使用本身提供的或指定的或採購的連接線,電源線和電源適配器。包含遵照當地法規和安全要求的合規的電源線尺寸和插頭。使用其它線材或適配器可能會引起故障或火災。除了Supermicro所指定的產品,電氣用品和材料安全法律規定禁止使用未經UL或CSA認證的線材。(線材上會顯示UL/CSA符號)。

### 警告

安裝此產品時,請使用本身提供的或指定的或採購的連接線,電源線和電源適配器。包含遵照當地法規和安全要求的合規的電源線尺寸和插頭。使用其它線材或適配器可能會引起故障或火災。除了Supermicro所指定的產品,電氣用品和材料安全法律規定禁止使用未經UL或CSA認證的線材。(線材上會顯示UL/CSA符號)。

### Warnung

Nutzen Sie beim Installieren des Produkts ausschließlich die von uns zur Verfügung gestellten Verbindungskabeln, Stromkabeln und/oder Adapter, die Ihre örtlichen Sicherheitsstandards einhalten. Der Gebrauch von anderen Kabeln und Adapter können Fehlfunktionen oder Feuer verursachen. Die Richtlinien untersagen das Nutzen von UL oder CAS zertifizierten Kabeln (mit UL/CSA gekennzeichnet), an Geräten oder Produkten die nicht mit Supermicro gekennzeichnet sind.

## ¡Advertencia!

Cuando instale el producto, utilice la conexión provista o designada o procure cables, Cables de alimentación y adaptadores de CA que cumplan con los códigos locales y los requisitos de seguridad, incluyendo el tamaño adecuado del cable y el enchufe. El uso de otros cables y adaptadores podría causar un mal funcionamiento o un incendio. La Ley de Seguridad de Aparatos Eléctricos y de Materiales prohíbe El uso de cables certificados por UL o CSA (que tienen el certificado UL / CSA en el código) para cualquier otros dispositivos eléctricos que los productos designados únicamente por Supermicro.Attention

## Attention

Lors de l'installation du produit, utilisez les cables de connection fournis ou désigné ou achetez des cables, cables de puissance et adaptateurs respectant les normes locales et les conditions de securite y compris les tailles de cables et les prises electriques appropriées. L'utilisation d'autres cables et adaptateurs peut provoquer un dysfonctionnement ou un incendie. Appareils électroménagers et la Loi sur la Sécurité Matériel interdit l'utilisation de câbles certifiés- UL ou CSA (qui ont UL ou CSA indiqué sur le code) pour tous les autres appareils électriques sauf les produits désignés par Supermicro seulement.

## AC כבלים חשמליים ומתאמי

!אזהרה

אשר נרכשו או AC כאשר מתקינים את המוצר, יש להשתמש בכבלים, ספקים ומתאמים הותאמו לצורך ההתקנה, ואשר הותאמו לדרישות הבטיחות המקומיות, כולל מידה נכונה של הכבל והתקע. שימוש בכל כבל או מתאם מסוג אחר, עלול לגרום לתקלה או קצר חשמלי. בהתאם לחוקי השימוש במכשירי החשמל וחוקי הבטיחות, קיים איסור להשתמש עבור UL/CSA) כאשר מופיע עליהם קוד של (UL-CSA או ב UL- בכבלים המוסמכים ב בלבד Supermicro כל מוצר חשמלי אחר, אלא רק במוצר אשר הותאם ע"י

عند تركيب المنتج، قم باستخدام التوصيلات المتوفرة أو المحددة أو قم بشراء الكابلات الكهربائية ومحوّلات التيار المتردد مع الالتزام بقوانين ومتطلبات السلامة المحلية بما في ذلك حجم الموصل والقابس السليم. استخدام أي كابلات ومحوّلات أخرى قد يتسبب في عطل أو حريق. يحظر قانون السلامة للأجهزة الكهربائية والمعدات استخدام مع أي معدات أخرى غير المنتجات المعنية (UL/CSA) والتي تحمل علامة CSA أو UL الكابلات المعتمدة من قبل Supermicro والمحددة من قبل

### 전원 케이블 및 AC 어댑터

경고! 제품을 설치할 때 현지 코드 및 적절한 굵기의 코드와 플러그를 포함한 안전 요구 사항을 준수하여 제공되거나 지정된 연결 혹은 구매 케이블, 전원 케이블 및 AC 어댑터를 사용하십시오.

다른 케이블이나 어댑터를 사용하면 오작동이나 화재가 발생할 수 있습니다. 전기 용품 안전법은 UL 또는 CSA 인증 케이블 (코드에 UL / CSA가 표시된 케이블)을 Supermicro가 지정한 제품 이외의 전기 장치에 사용하는 것을 금지합니다.

### Stroomkabel en AC-Adapter

Waarschuwing! Bij het aansluiten van het Product uitsluitend gebruik maken van de geleverde Kabels of een andere geschikte aan te schaffen Aansluitmethode, deze moet altijd voldoen aan de lokale voorschriften en veiligheidsnormen, inclusief de juiste kabeldikte en stekker. Het gebruik van niet geschikte Kabels en/of Adapters kan een storing of brand veroorzaken. Wetgeving voor Elektrische apparatuur en Materiaalveiligheid verbied het gebruik van UL of CSA -gecertificeerde Kabels (met UL/CSA in de code) voor elke andere toepassing dan de door Supermicro hiervoor beoogde Producten.



## Chapter 5

### Advanced Serverboard Setup

This chapter covers the steps required to install the X10DRL-i serverboard into the SC813MFTQ-400CB/R400CB chassis, connect the data and power cables and install add-on cards. All serverboard jumpers and connections are also described. A layout and quick reference chart are included in this chapter for your reference. Remember to completely close the chassis when you have finished working with the serverboard to better cool and protect the system.

#### 5-1 Handling the Serverboard

Electrostatic Discharge (ESD) can damage electronic components. To prevent damage to any printed circuit boards (PCBs), it is important to handle them very carefully (see previous chapter). To prevent the X10DRL-i serverboard from bending, keep one hand under the center of the board to support it when handling. The following measures are generally sufficient to protect your equipment from electric static discharge.

##### Precautions

- Use a grounded wrist strap designed to prevent Electrostatic Discharge (ESD).
- Touch a grounded metal object before removing any board from its antistatic bag.
- Handle a board by its edges only; do not touch its components, peripheral chips, memory modules or gold contacts.
- When handling chips or modules, avoid touching their pins.
- Put the serverboard, add-on cards and peripherals back into their antistatic bags when not in use.
- For grounding purposes, make sure your computer chassis provides excellent conductivity between the power supply, the case, the mounting fasteners and the serverboard.

## Unpacking

The serverboard is shipped in antistatic packaging to avoid electrical static discharge. When unpacking the board, make sure the person handling it is static protected.

## 5-2 Connecting Cables

Now that the serverboard is installed, the next step is to connect the cables to the board. These include the data cables for the peripherals and control panel and the power cables.

### Connecting Data Cables

The cables used to transfer data from the peripheral devices have been carefully routed to prevent them from blocking the flow of cooling air that moves through the system from front to back. If you need to disconnect any of these cables, you should take care to keep them routed as they were originally after reconnecting them (make sure the red wires connect to the pin 1 locations).

The following data cables (with their locations noted) should be connected. (See the layout on page 5-9 for connector locations.)

- SATA drive cables (I-SATA0 ~ I-SATA3)
- SGPIO cables (I-SGPIO1)
- Control Panel cable (JF1)

### Connecting Power Cables

The X10DRL-i has a 24-pin primary power supply connector (J24) for connection to the ATX power supply. In addition, there are two 8-pin processor power connectors (JPWR1/JPWR2) that also must be connected to your power supply. See Section 5-8 for power connector pin definitions.

### Connecting the Control Panel

JF1 contains header pins for various front control panel connectors. See Figure 5-1 for the pin locations of the various front control panel buttons and LED indicators. All JF1 wires have been bundled into a single ribbon cable to simplify this connection. Make sure the red wire plugs into pin 1 as marked on the board. The other end connects to the Control Panel PCB board, located just behind the system status LEDs on the chassis.

Figure 5-1. Control Panel Header Pins

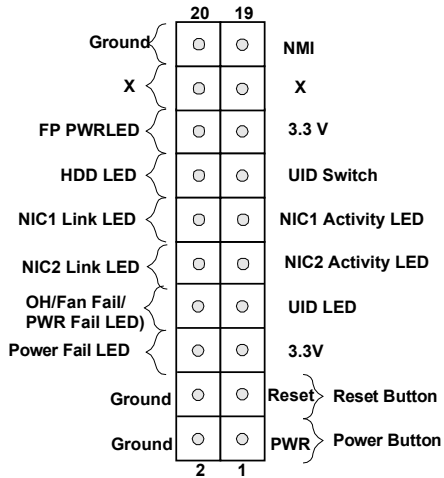

### 5-3 Rear I/O Ports

See Figure 5-2 below for the locations of the various I/O ports located on the back panel of the serverboard.

Figure 5-2. Rear I/O Ports

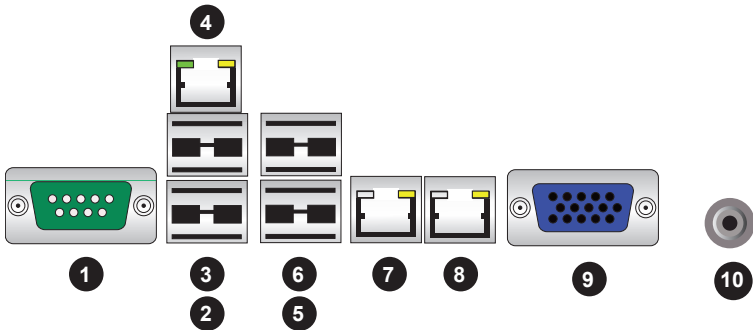

Rear I/O Ports	
1. COM1 Port	6. USB 3.0
2. USB 2.0	7. LAN1
3. USB 2.0	8. LAN2
4. Dedicated IPMI LAN	9. VGA Port
5. USB 3.0	10. UID Button/LED

## 5-4 Installing the Processor and Heatsink

**Caution:** When handling the processor package, avoid placing direct pressure on the label area of the fan.

**Notes:**

- Always connect the power cord last and always remove it before adding, removing or changing any hardware components. Make sure that you install the processor into the CPU socket before you install the CPU heatsink.
- If you buy a CPU separately, make sure that you use an Intel-certified multi-directional heatsink only.
- Make sure to install the serverboard into the chassis before you install the CPU heatsinks.
- When receiving a serverboard without a processor pre-installed, make sure that the plastic CPU socket cap is in place and none of the socket pins are bent; otherwise, contact your retailer immediately.
- Refer to the Supermicro web site for updates on CPU support.

### Installing an LGA 2011 Processor

1. There are two levers on the LGA2011 socket. First press and release the load lever labeled 'Open 1st'.
2. Press the second load lever labeled 'Close 1st' to release the load plate from its locked position.

Press down on the lever labeled  
'Close 1st'

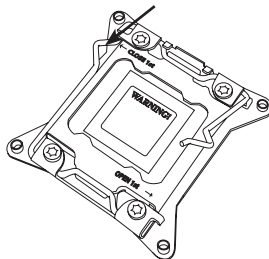

Pull lever away  
from the socket

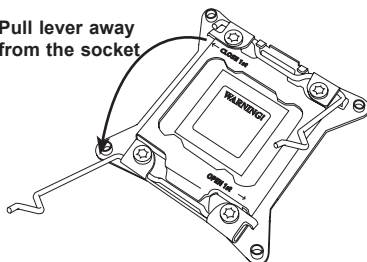

3. With the lever labeled 'Close 1st' fully retracted, gently push down on the 'Open 1st' lever to open the load plate. Lift the load plate to open it completely.
4. Using your thumb and the index finger, remove the 'WARNING' plastic cap from the socket.
5. Use your thumb and index finger to hold the CPU by its edges. Align the CPU keys, which are semi-circle cutouts, against the socket keys.
6. Once they are aligned, carefully lower the CPU straight down into the socket. (Do not drop the CPU on the socket. Do not move the CPU horizontally or vertically and do not rub the CPU against any pins of the socket, which may damage the CPU or the socket.)

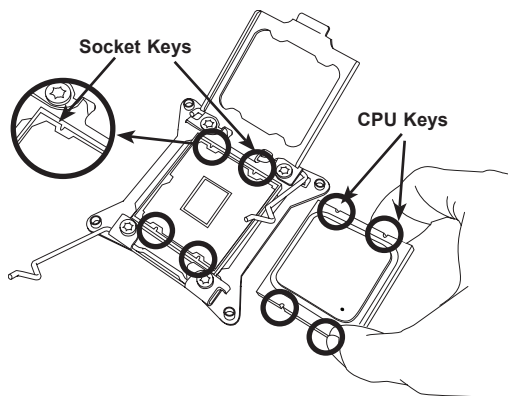
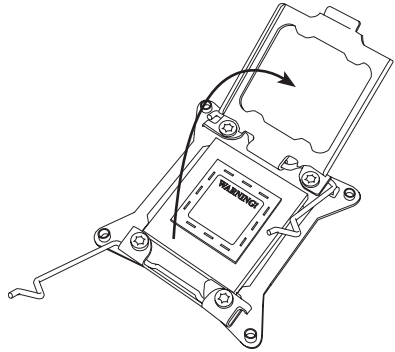
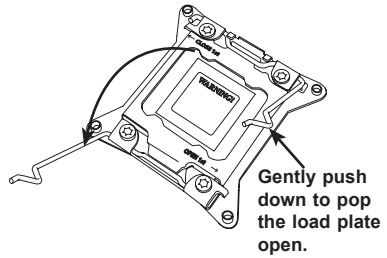

**Caution:** You can only install the CPU to the socket in one direction. Make sure that the CPU is properly inserted into the socket before closing the load plate. If it doesn't close properly, do not force it as it may damage your CPU. Instead, open the load plate again and double-check that the CPU is aligned properly.

7. With the CPU in the socket, inspect the four corners of the CPU to make sure that they are flush with the socket.
8. Close the load plate. Lock the lever labeled 'Close 1st', then lock the lever labeled 'Open 1st'. Use your thumb to gently push the load levers down until the lever locks.
9. Repeat steps to install to the remaining CPU socket.

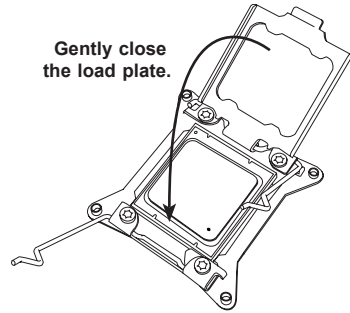

Push down and lock the level labeled 'Close 1st'.

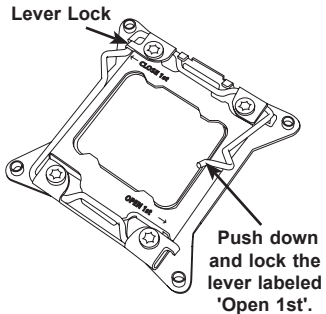
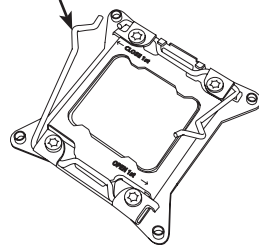

## Installing a Passive CPU Heatsink

1. Do not apply any thermal grease to the heatsink or the CPU die -- the required amount has already been applied.
2. Place the heatsink on top of the CPU so that the four mounting holes are aligned with those on the serverboard and the heatsink bracket underneath.
3. Screw in two diagonal screws (i.e., the #1 and the #2 screws) until just snug (do not over-tighten the screws to avoid possible damage to the CPU.)
4. Add the two remaining screws then fully tighten all four screws.

## Removing the Heatsink

**Caution:** We do not recommend removing the CPU or the heatsink. However, if you do need to remove the heatsink, please follow the instructions below to prevent damage to the CPU or other components.

1. Unscrew the heatsink screws from the serverboard in the sequence shown above.
2. Gently wriggle the heatsink to loosen it from the CPU (do not use excessive force). Once the CPU is loose, remove the it from the CPU socket.
3. Clean the surface of the CPU and the heatsink, removing the used thermal grease. Reapply the proper amount of thermal grease on the surface before re-installing the CPU and the heatsink.

Figure 5-3. Installing the Heatsink

Loosen screws  
in sequence as  
shown.

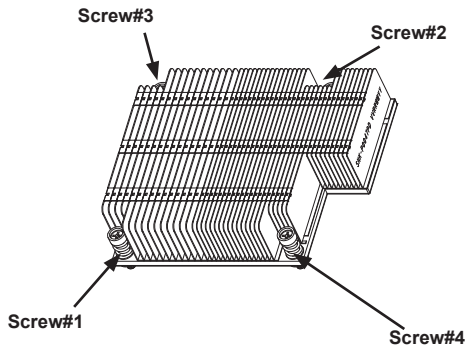

## 5-5 Installing Memory Modules

**Note:** Check the Supermicro web site for recommended memory modules.

---

### **CAUTION**

Exercise extreme care when installing or removing DIMMs to prevent any possible damage.

---

### **Installing & Removing DIMMs**

1. Insert the desired number of DIMMs into the memory slots, starting with DIMM A1. For best performance, please use the memory modules of the same type and same speed in the same bank. See the DIMM Installation Charts on the following pages.
2. Push the release tabs outwards on the ends of a memory slot. Insert each DIMM vertically into the slot. Pay attention to the notch along the bottom of the module to prevent inserting the DIMM incorrectly.
3. Gently press down on the DIMM until it snaps into place in the slot. Repeat for all modules.
4. To remove a DIMM, push out the release tabs to unlock it. Once the DIMM is unlocked, remove it from the memory slot.

**Figure 5-4. DIMM Installation**

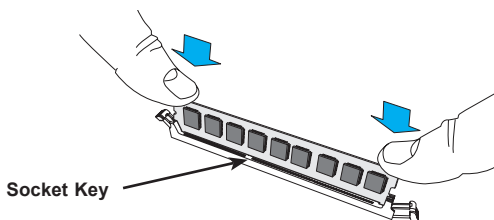



## Memory Support for the X10DRL-i Serverboard

The X10DRL-i supports up to 1 TB of ECC LRDIMM (Load-Reduced DIMMs) or 512 GB of ECC RDIMM (registered DIMMs) DDR4-2400/2133/1866/1600 memory in eight DIMM slots. Memory speed is dependent on the CPU. For the latest memory updates, please refer to our website.

### Processor & Memory Module Population Configuration

For memory to work properly, follow the tables below for memory installation.

Processors and their Corresponding Memory Modules				
CPU#	Corresponding DIMM Modules			
CPU 1	P1-DIMMA1	P1-DIMMB1	P1-DIMMC1	P1-DIMMD1
CPU 2	P2-DIMME1	P2-DIMMF1	P2-DIMMG1	P2-DIMMH1

Processor and Memory Module Population for Optimal Performance	
Number of CPUs+DIMMs	CPU and Memory Population Configuration Table (For memory to work properly, please follow the instructions below.)
1 CPU & 2 DIMMs	CPU1 P1-DIMMA1/P1-DIMMB1
1 CPU & 4 DIMMs	CPU1 P1-DIMMA1/P1-DIMMB1, P1-DIMMC1/P1-DIMMD1
2 CPUs & 4 DIMMs	CPU1 + CPU2 P1-DIMMA1/P1-DIMMB1, P2-DIMME1/P2-DIMMF1
2 CPUs & 6 DIMMs	CPU1 + CPU2 P1-DIMMA1/P1-DIMMB1/P1-DIMMC1/P1-DIMMD1, P2-DIMME1/P2-DIMMF1
2 CPUs & 8 DIMMs	CPU1 + CPU2 P1-DIMMA1/P1-DIMMB1/P1-DIMMC1/P1-DIMMD1, P2-DIMME1/P2-DIMMF1/P2-DIMMG1/P2-DIMMH1

Populating RDIMM/LRDIMM DDR4 Memory Modules					
Type	Ranks Per DIMM and Data Width	DIMM Capacity (GB)		Speed (MT/s); Voltage (V); Slots per Channel (SPC) and DIMMs per Channel (DPC)	
				1 Slot per Channel	
				1 DPC	
				E5-2600 V3	E5-2600 V4
		4 Gb	8 Gb	1.2 V	1.2 V
RDIMM	SRx4	8 GB	16 GB	2133	2400
RDIMM	SRx8	4 GB	8 GB	2133	2400
RDIMM	DRx8	8 GB	16 GB	2133	2400
RDIMM	DRx4	16 GB	32 GB	2133	2400
LRDIMM	QRx4	32 GB	64 GB	2133	2400
LRDIMM 3DS	8Rx4	64 GB	128 GB	2133	2400

## 5-6 Adding PCI Cards

The 6018R-MT/6087R-MTR includes an RSC-RR1U-E8 riser card, which fits into a PCI-E slot to support a full-height half-length PCI Express expansion card.

### ***PCI Card Installation***

When installing a PCI add-on card, make sure you install it into a slot that supports the speed of the card.

1. Swing out the release tab on the PCI-E slot shield.
2. Insert the PCI-E card into the riser card, pushing down with your thumbs evenly on both sides of the card.
3. Finish by pushing the release tab back to its original (locked) position.

## 5-7 Serverboard Details

Figure 5-5. X10DRL-i Layout

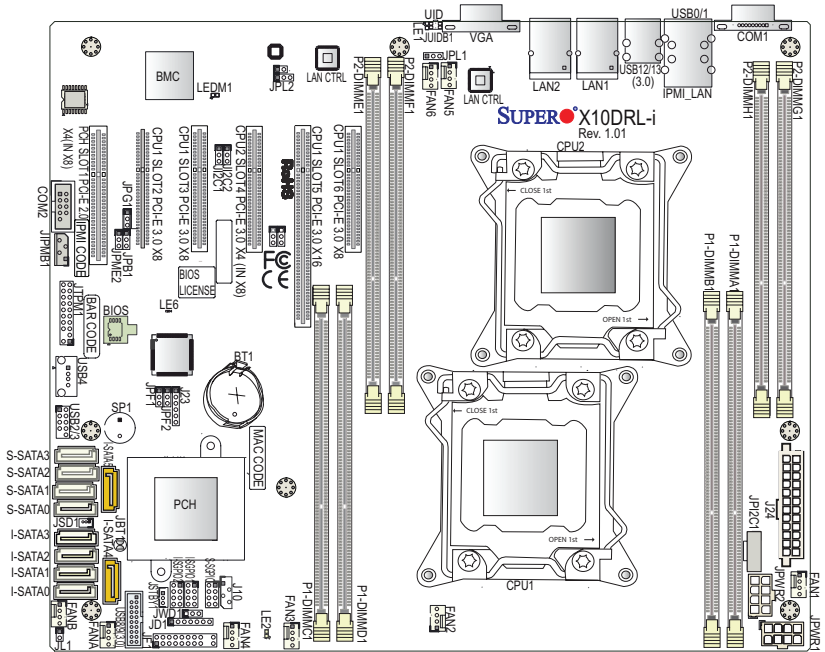

**Notes:** Jumpers not indicated are for test purposes only. A square contact pad indicates the location of pin 1.

### X10DRL-i Quick Reference Table

LED	Description	State	Status
LE1	Rear UID LED	Blue: On	Unit Identified
LE2	Onboard PWR LED	On	System Power On
LEDM1	BMC Heartbeat LED	Green: Blinking	BMC Normal
Jumper	Description	Default Setting	
JBT1	Clear Onboard CMOS Battery	See Section 5-9	
J1 <sup>2</sup> C1/ J1 <sup>2</sup> C2	SMB to PCI-E Slots	Pins 2-3 (Disabled)	
JPB1	BMC Enable	Pins 1-2 (Enabled)	
JPG1	VGA Enable	Pins 1-2 (Enabled)	
JPL1/JPL2	GLAN1/GLAN2 Enable	Pins 1-2 (Enabled)	
JPME2	ME Manufacturing Mode Select	Pins 1-2 (Normal)	
JWD1	Watch Dog Timer Enable	Pins 1-2 (Reset)	

<b>Connector</b>	<b>Description</b>
BT1	Onboard Battery
COM1/COM2	Back Panel COM Port/Front Accessible COM Header
Fan1-6, FanA/B	CPU/System Fan Headers
J24	24-pin ATX Main Power Connector
JD1	Speaker/Power LED
JF1	Front Panel Control Header
JIPMB1	4-pin External BMC I <sup>2</sup> C Header (for an IPMI Card)
JL1	Chassis Intrusion
JPI <sup>2</sup> C1	Power Supply SMBbus I <sup>2</sup> C Header
JPWR1/JPWR2	12V 8-Pin Power Connectors
JSD1	SATA DOM (Device on Module) Power Connector
JSTBY1	Standby Power Connector
JTPM1	TPM (Trusted Platform Module)/Port 80 Header
JUIDB1	UID (Unit Identification) Button
LAN1/LAN2	G-bit Ethernet (GLAN) Ports 1/2
IPMI_LAN	IPMI_Dedicated LAN support by the Aspeed Controller
I-SATA 0-5	SATA 3.0 Ports supported by Intel PCH (I-SATA 0-5)
S-SATA 0-3	SATA 3.0 Ports supported by Intel SCU (S-SATA 0-3)
(PCH) Slot1	PCI-Express 2.0 x4 in x8 Slot from Intel PCH
(CPU1) Slot2	PCI-Express 3.0 x8 Slot from CPU1
(CPU1) Slot3	PCI-Express 3.0 x8 Slot from CPU1
(CPU2) Slot4	PCI-Express 3.0 x4 in x8 Slot from CPU2
(CPU1) Slot5	PCI-Express 3.0 x16 Slot from CPU1
(CPU1) Slot6	PCI-Express 3.0 x8 Slot from CPU1
I-SGPIO1/2	Serial Link General Purpose I/O Headers 1/2 (I-SGPIO1 for I-SATA0-3, I-SGPIO2 for I-SATA4/5)
S-SGPIO	Serial Link General Purpose I/O Header (for S-SATA0-3)
SP1	Internal Speaker/Buzzer
USB 0/1	Backpanel USB 2.0 Ports 0/1
USB 12/13 (3.0)	Backpanel USB 3.0 Ports 12/13
USB 2/3	Front-Accessible USB 2.0 Connection Header 2/3
USB 4	Front-Accessible Type A Connector USB 2.0 Port 4
USB 8/9 (3.0)	Front-Accessible USB 3.0 Connection Header 8/9
VGA	Backpanel VGA Port

## 5-8 Connector Definitions

### ATX Power Connector

The primary power supply connector (J24) on the X10DRL-i meets the SSI EPS 12V specification. Refer to the table on the right for the pin definitions of this power connector.

You must also connect the 8-pin processor power connectors (JPWR1/JPWR2) to your power supply see below).

ATX Power 24-pin Connector Pin Definitions			
Pin#	Definition	Pin #	Definition
13	+3.3V	1	+3.3V
14	-12V	2	+3.3V
15	COM	3	COM
16	PS_ON	4	+5V
17	COM	5	COM
18	COM	6	+5V
19	COM	7	COM
20	Res (NC)	8	PWR_OK
21	+5V	9	5VSB
22	+5V	10	+12V
23	+5V	11	+12V
24	COM	12	+3.3V

### Processor Power Connector

In addition to J24, the 12V 8-pin processor power connectors at JPWR1 and JPWR2 must be connected. Failure in doing so will void the manufacturer warranty on your power supply and serverboard. See the table on the right for pin definitions.

Processor Power Connector Pin Definitions	
Pins	Definition
1 through 4	Ground
5 through 8	+12V

#### Required Connection

### Power Button

The power button connection on pins 1 and 2 of JF1 connects to the chassis power button. Momentarily depressing this button will power on/off the system. This button can also be configured to function as a suspend button (with a BIOS setting). To turn off the power when the system is in suspend mode, press the button for 4 seconds or longer. See the table on the right for pin definitions.

Power Button Pin Definitions	
Pin#	Definition
1	Signal
2	Ground

### Reset Button

The reset button connector is located on pins 3 and 4 of JF1 and attaches to the reset switch on the computer chassis. See the table on the right for pin definitions.

Reset Button Pin Definitions	
Pin#	Definition
3	Reset
4	Ground

### Power Fail LED

The Power Fail LED connection is located on pins 5 and 6 of JF1. Refer to the table on the right for pin definitions.

PWR Fail LED Pin Definitions	
Pin#	Definition
5	3.3V
6	Signal

### Overheat (OH)/Fan Fail/PWR Fail/ UID LED

Connect an LED cable to pins 7 and 8 of Front Control Panel to use the Overheat/Fan Fail/Power Fail and UID LED connections. The red LED (pin 8) provides warnings of overheat, fan failure or power failure. The blue LED on (pin 8) works as the front panel UID LED indicator. Refer to the tables for more information.

OH/Fan Fail/ PWR Fail/Blue_UID LED Pin Definitions	
Pin#	Definition
7	Red_LED-Cathode/OH/Fan Fail/ Power Fail5.SV.SB
8	Blue_UID LED

OH/Fan Fail/PWR Fail LED Status (Red LED)	
State	Definition
Off	Normal
On	Overheat
Flashing	Fan Fail

### NIC2 (LAN2) LED

The LED connections for LAN2 are on pins 9 and 10 of JF1. Attach LAN LED cables to display network activity. See the table on the right for pin definitions.

NIC2 LED Pin Definitions	
Pin#	Definition
9	Activity
10	Link

### NIC1 (LAN1) LED

The LED connections for LAN1 are on pins 11 and 12 of JF1. Attach LAN LED cables to display network activity. See the table on the right for pin definitions.

NIC1 LED Pin Definitions	
Pin#	Definition
11	Activity
12	Link

### HDD LED

The HDD LED connection is located on pins 13 and 14 of JF1. Pin 14 is for HDD activity and pin 13 is for the UID switch. See the table on the right for pin definitions.

HDD LED/UID Switch Pin Definitions	
Pin#	Definition
13	UID Switch
14	HD Activity

## Power On LED

The Power On LED connector is located on pins 15 and 16 of JF1. This connection is used to provide LED indication of power being supplied to the system. See the table on the right for pin definitions.

Power LED Pin Definitions	
Pin#	Definition
15	3.3V
16	PWR LED

## NMI Button

The non-maskable interrupt button header is located on pins 19 and 20 of JF1. Refer to the table on the right for pin definitions.

NMI Button Pin Definitions	
Pin#	Definition
19	Control
20	Ground

## Fan Headers

There are eight fan headers on the X10DRL-i. All are 4-pin fans but are backward compatible with traditional 3-pin fans. Fan speed control via IPMI is available for 4-pin fans only. See the table on the right for pin definitions.

Fan Header Pin Definitions	
Pin#	Definition
1	Ground (Black)
2	+12V (Red)
3	Tachometer
4	PWM Control

## Chassis Intrusion

The Chassis Intrusion header is designated JL1. See the board layout for the location of JL1 and the table on the right for pin definitions.

Chassis Intrusion Pin Definitions	
Pin#	Definition
1	Intrusion Input
2	Ground

## Serial Ports

Two serial ports are included on the serverboard: COM1 is a port located on the rear I/O panel and COM2 is a header (located near PCI-E slot 1) for front access support. See the table on the right for pin definitions.

Serial Port Pin Definitions			
Pin #	Definition	Pin #	Definition
1	DCD	6	DSR
2	RXD	7	RTS
3	TXD	8	CTS
4	DTR	9	RI
5	Ground	10	NC

**Note:** Pin 10 is included on the header but not on the port. NC indicates no connection.

## Universal Serial Bus (USB)

Two USB 2.0 and two USB 3.0 ports are located on the rear I/O panel. A USB header (USB2/3) and a Type A USB connector (USB4) are onboard USB 2.0 connections. In addition, a USB 3.0 header (USB8/9) is also on the serverboard to provide front side USB access (cables not included). See the tables on the right and below for pin definitions.

USB8/9, 12/13 Pin Definitions (USB 3.0)			
Pin#	Description	Pin#	Description
1	USB3.0_Front_VCC		
2	USB3_RE_RXN6	19	USB3.0_Front_VCC
3	USB3_RE_RXP6	18	USB3_RE_RXN5
4	Ground	17	USB3_RE_RXP5
5	USB3_RE_TXN6	16	Ground
6	USB3_RE_TXP6	15	USB3_RE_TXN5
7	Ground	14	USB3_RE_TXP5
8	USB2_N8	13	Ground
9	USB2_P8	12	USB2_N9
10	Ground	11	USB2_P9

## Power SMB (I<sup>2</sup>C) Connector

Power System Management Bus (I<sup>2</sup>C) Connector (JPI<sup>2</sup>C1) monitors power supply, fan and system temperatures. See the table on the right for pin definitions.

## IPMB

IPMB (JIPMB1) is a System Management Bus header for IPMI 2.0. Connect the appropriate cable here to use the IPMB I<sup>2</sup>C connection on your system.

Back Panel USB0/1 Pin Definitions (USB 2.0)			
Pin#	Definition	Pin#	Definition
1	+5V	5	+5V
2	USB_PN0	6	USB_PN1
3	USB_PP0	7	USB_PP1
4	Ground	8	Ground

USB2/3 Pin Definitions (USB 2.0)			
Pin #	Definition	Pin #	Definition
1	+5V	2	+5V
3	USB_PN2	4	USB_PN3
5	USB_PP2	6	USB_PP3
7	Ground	8	Ground
9	Key	10	No Connection

USB4 Pin Definitions (USB 2.0)	
Pin#	Description
1	+5V
2	USB_PN4
3	USB_PP4
4	Ground

PWR SMB Pin Definitions	
Pin#	Definition
1	Clock
2	Data
3	PMBUS_Alert
4	Ground
5	+3.3V

IPMB Header Pin Definitions	
Pin#	Definition
1	Data
2	Ground
3	Clock
4	No Connection



## SGPIO Headers

Three SGPIO (Serial General Purpose Input/Output) headers are included on the serverboard. These headers are used to communicate with the System Monitoring chip on the backplane and provide a serial interface to the SATA ports. I-SGPIO 1/2 supports the I-SATA ports while S-SGPIO supports the S-SATA ports. See the table on the right for pin definitions.

SGPIO Headers Pin Definitions			
Pin#	Definition	Pin	Definition
1	NC	2	NC
3	Ground	4	Data
5	Load	6	Ground
7	Clock	8	No Connection

I-SGPIO0/1 & S-SGPIO Support	
I-SGPIO1	I-SATA Ports 0/1/2/3 Supported
I-SGPIO2	I-SATA Ports 4/5 Supported
S-SGPIO	S-SATA Ports 0/1/2/3 Supported

## DOM Power Connector

A power connector for SATA DOM (Disk On Module) devices is located at JSD1. Connect an appropriate cable here to provide power support for your Serial Link DOM devices.

DOM PWR Pin Definitions	
Pin#	Definition
1	+5V
2	Ground
3	Ground

## TPM/Port 80 Header

A Trusted Platform Module/Port 80 header is located at JTPM1 to provide TPM support and Port 80 connection. Use this header to enhance system performance and data security. See the table on the right for pin definitions.

TPM/Port 80 Header Pin Definitions			
Pin #	Definition	Pin #	Definition
1	LCLK	2	GND
3	LFRAME#	4	<(KEY)>
5	LRESET#	6	+5V (X)
7	LAD 3	8	LAD 2
9	+3.3V	10	LAD1
11	LAD0	12	GND
13	SMB_CLK4	14	SMB_DAT4
15	+3V_DUAL	16	SERIRQ
17	GND	18	CLKRUN# (X)
19	LPCPD#	20	LDRQ# (X)

## Onboard Speaker (SP1)

The onboard speaker provides audible indications for various beep codes. See the table on the right for pin definitions.

Onboard Speaker Pin Definition		
Pin#	Definitions	
Pin 1	Pos. (+)	Beep In
Pin 2	Neg. (-)	Alarm Speaker

### LAN1/2 (Ethernet Ports)

Two gigabit Ethernet ports (LAN1 and LAN2) are located on the rear I/O panel. These ports accept RJ45 type cables. The X10DRL-i also includes a dedicated IPMI LAN port above the rear USB ports.

LAN Port Pin Definition			
Pin#	Definition	Pin#	Definition
1	Ground	9	TD1+
2	VCC	10	TD1-
3	TD4+	11	Link 1000 LED (Orange)
4	TD4-	12	Link 100 LED (Green)
5	TD3+	13	Act LED (Yellow+)
6	TD3-	14	Act LED (Yellow-)
7	TD2+	15	Ground
8	TD2-	16	Ground

### Unit Identifier Switch/UID LED Indicators

A Unit Identifier button (JUIDB), a backplane LED indicator and a front panel UID header are provided on the serverboard. The UID button is located next to the VGA port on the backplane. The rear UID LED indicator (LED1) is located next to the UID button. The front UID switch connector is located on pin 13 of JF1. The rear UID LED (LE1) is located next to the UID switch and its connection is located on pin 7 on JF1.

When you press the UID button, the rear UID LED will turn on. Press the UID button again to turn off the LED. The UID indicator provides easy identification of a system that may be in need of service.

**Note:** UID can also be triggered via IPMI on the serverboard. For more information on IPMI, please refer to the IPMI User's Guide posted on our website: <http://www.supermicro.com>.

UID Switch Pin Definitions	
Pin#	Definition
1	Ground
2	Ground
3	Button In
4	Button In

UID LED Status	
Color/State	Status
Blue: On	Unit Identified

### Power LED/Speaker

Pins 1-3 of JD1 are used for power LED indication and pins 4-7 are for the speaker. See the tables on the right for pin definitions. Please note that the speaker connector pins (4-7) are used with an external speaker. If you wish to use the onboard speaker, you should close pins 6-7 with a jumper.

PWR LED Connector Pin Definitions	
Pin Setting	Definition
Pin 1	JD1_PIN1
Pin 2	FP_PWR_LED
Pin 3	FP_PWR_LED

Speaker Connector Pin Settings	
Pin Setting	Definition
Pin 4	P5V
Pin 5	No Connection
Pin 6	R_SPKRIN_N
Pin 7	R_SPKRIN

### Standby Power Header

The +5V Standby Power header is located at JSTBY1. See the table on the right for pin definitions. (You must also have a card with a Standby Power connector and a cable to use this feature.)

Standby PWR Pin Definitions	
Pin#	Definition
1	+5V Standby
2	Ground
3	No Connection

## 5-9 Jumper Settings

### Explanation of Jumpers

To modify the operation of the serverboard, jumpers can be used to choose between optional settings. Jumpers create shorts between two pins to change the function of the connector. Pin 1 is identified with a square solder pad on the printed circuit board. See the serverboard layout pages for jumper locations.

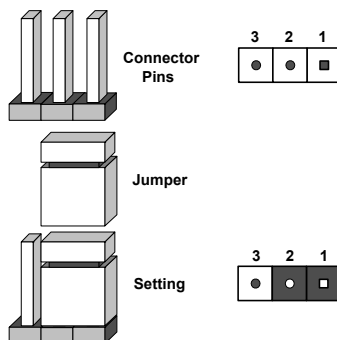

**Note:** On a two-pin jumper, "Closed" means the jumper is on both pins and "Open" means the jumper is either on only one pin or completely removed.

### CMOS Clear

JBT1 is used to clear CMOS (and will also clear any passwords). This jumper consists of contact pads to prevent accidentally clearing the contents of CMOS.

To clear CMOS:

1. First power down the system and unplug the power cord(s).
2. With the power disconnected, short the CMOS pads with a metal object such as a small screwdriver.
3. Remove the screwdriver (or shorting device).
4. Reconnect the power cord(s) and power on the system

**Note:** Do not use the PW\_ON connector to clear CMOS.

### BMC Enable

Jumper JPB1 allows you to enable the embedded BMC (Baseboard Management Controller) to provide IPMI 2.0/ KVM support. See the table on the right for jumper settings. The default setting is enabled.

BMC Enable Jumper Settings	
Jumper Setting	Definition
Pins 1-2	BMC Enabled
Pins 2-3	Disabled

### LAN1/LAN2 Enable/Disable

Change the setting of jumper JPL1 and JPL2 to enable or disable the LAN1 and LAN2 ports, respectively. The default setting is enabled.

LAN1/2 Enable/Disable Jumper Settings	
Jumper Setting	Definition
Pins 1-2	Enabled
Pins 2-3	Disabled

### VGA Enable/Disable

JPG1 allows you to enable or disable the onboard VGA port. The default position is on pins 1 and 2 to enable VGA. See the table on the right for jumper settings.

VGA Enable/Disable Jumper Settings	
Jumper Setting	Definition
Pins 1-2	Enabled
Pins 2-3	Disabled

### Watch Dog

JWD1 enables the Watch Dog function, a system monitor that takes action when a software application freezes the system. Jumping pins 1-2 (default) will have WD reboot the system if a program freezes. Jumping pins 2-3 will generate a non-maskable interrupt for the program that has frozen. See the table on the right for jumper settings. Watch Dog must also be enabled in BIOS.

Watch Dog Jumper Settings	
Jumper Setting	Definition
Pins 1-2	Reset
Pins 2-3	NMI
Open	Disabled

**Note:** when Watch Dog is enabled, the user must write their own application software to disable the Watch Dog Timer.

### I<sup>2</sup>C Bus to PCI/PCI-Exp. Slots

Jumpers JI<sup>2</sup>C1 and JI<sup>2</sup>C2 allow you to connect the System Management Bus (I<sup>2</sup>C) to the PCI-E slots to improve PCI performance. The default setting is closed (enabled.) Both jumpers must be set to the same setting. See the table on the right for jumper settings.

I <sup>2</sup> C to PCI/PCI-E Slots Jumper Settings		
Jumper Settings		Definition
JI <sup>2</sup> C1: Closed	JI <sup>2</sup> C2: Closed	Enabled
JI <sup>2</sup> C1: Open	JI <sup>2</sup> C2: Open	Disabled

### ME Manufacturing Mode Select

Close pins 2 and 3 of jumper JPME2 to bypass SPI flash security and force the system to operate in Manufacturer mode. This allows the user to flash the system firmware from a host server for system setting modifications. See the table on the right for jumper settings.

ME Mode Select Jumper Settings	
Jumper Setting	Definition
Pins 1-2	Normal (Default)
Pins 2-3	Manufacture Mode

## 5-10 Onboard Indicators

### LAN Port LEDs

The LAN1/2 and the dedicated IPMI Ethernet ports all have two LEDs. One LED indicates activity when blinking while the other LED may be green, amber or off to indicate the speed of the connection. See the table on the right for the functions associated with the connection speed LED.



LAN LED (Connection Speed Indicator)	
LED Color	Definition
Off	No Connection or 10 Mb/s
Green	100 Mb/s
Amber	1 Gb/s

### Rear UID LED

The rear UID LED (LE1) is located on the rear near the rear I/O ports. This LED is used in conjunction with the UID switch to provide easy identification of a system in a server rack.

### Onboard Power LED

An Onboard Power LED is located at LE2 on the serverboard. When this LED is on, the system is on. Be sure to turn off the system and unplug the power cord before removing or installing components. See the table at right for more information.

Onboard PWR LED Indicator LED States	
LED Color	Definition
Off	System Off (PWR cable not connected)
Green	System On
Green: Flashing Quickly	ACPI S1 State

### BMC Heartbeat LED

A BMC Heartbeat LED is located at LEDM1 on the serverboard. When LEDDM1 is blinking, BMC functions normally. See the table at right for more information.

BMC Heartbeat LED States	
Color/State	Definition
Green: Blinking	BMC: Normal

## 5-11 SATA Ports

### SATA 3.0 Ports

Ten SATA 3.0 ports are provided on the serverboard. Six (I-SATA 0-5) are supported by the Intel SCU in the PCH C612. The other four (S-SATA 0-3) are supported by the Intel SCU. See the table on the right for pin definitions.

I-SATA 4 and I-SATA 5 also support SATA DOM (Device on Module) devices.

SATA Port Pin Definitions	
Pin #	Definition
1	Ground
2	TXP
3	TXN
4	Ground
5	RXN
6	RXP
7	Ground

## 5-12 Installing Software

The Supermicro website contains drivers and utilities for your system at <https://www.supermicro.com/wftp/driver>. Some of these must be installed, such as the chipset driver.

After accessing the website, go into the CDR\_Images (in the parent directory of the above link) and locate the ISO file for your motherboard. Download this file to a USB flash drive or a DVD. (You may also use a utility to extract the ISO file if preferred.)

Another option is to go to the Supermicro website at <http://www.supermicro.com/products/>. Find the product page for your motherboard, and "Download the Latest Drivers and Utilities".

Insert the flash drive or disk and the screenshot shown below should appear.

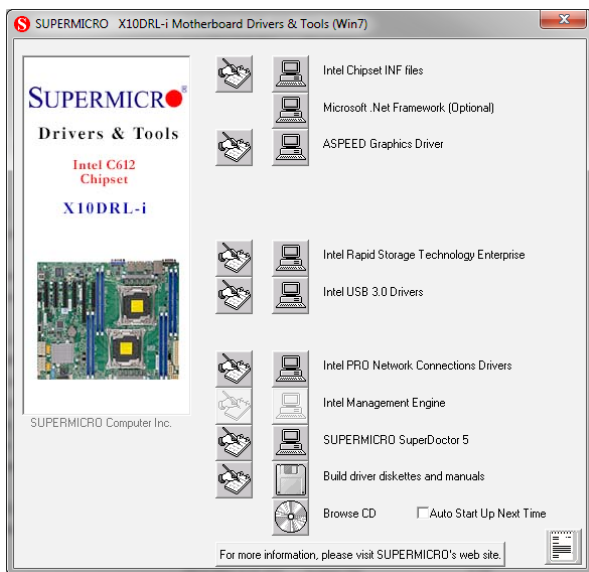

Figure 5-6. Driver/Tool Installation Display Screen

**Note:** Click the icons showing a hand writing on paper to view the readme files for each item. Click the computer icons to the right of these items to install each item (from top to the bottom) one at a time. **After installing each item, you must re-boot the system before moving on to the next item on the list.** The bottom icon with a CD on it allows you to view the entire contents.



## SuperDoctor® 5

The Supermicro SuperDoctor 5 is a program that functions in a command-line or web-based interface in Windows and Linux operating systems. The program monitors system health information such as CPU temperature, system voltages, system power consumption, fan speed, and provides alerts via email or Simple Network Management Protocol (SNMP).

SuperDoctor 5 comes in local and remote management versions and can be used with Nagios to maximize your system monitoring needs. With SuperDoctor 5 Management Server (SSM Server), you can remotely control power on/off and reset chassis intrusion for multiple systems with SuperDoctor 5 or IPMI. SD5 Management Server monitors HTTP, FTP, and SMTP services to optimize the efficiency of your operation.

**Note:** The default User Name and Password for SuperDoctor 5 is admin / admin.

**Figure 5-7. SuperDoctor 5 Interface Display Screen (Health Information)**



**Note:** The SuperDoctor 5 program and User's Manual can be downloaded from the Supermicro website at [http://www.supermicro.com/products/info/sms\\_sd5.cfm](http://www.supermicro.com/products/info/sms_sd5.cfm).

## 5-13 Onboard Battery

Please handle used batteries carefully. Do not damage the battery in any way; a damaged battery may release hazardous materials into the environment. Do not discard a used battery in the garbage or a public landfill. Please comply with the regulations set up by your local hazardous waste management agency to dispose of your used battery properly.

**Figure 5-8. Installing the Onboard Battery**

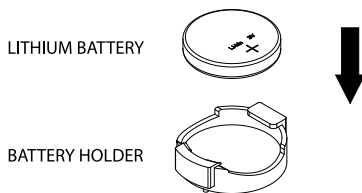

## Chapter 6

### Advanced Chassis Setup

This chapter covers the steps required to install components and perform maintenance on the SC813MFTQ chassis. For component installation, follow the steps in the order given to eliminate the most common problems encountered. If some steps are unnecessary, skip ahead to the step that follows.

**Tools Required:** The only tool you will need to install components and perform maintenance is a Philips screwdriver.

#### 6-1 Static-Sensitive Devices

Electrostatic Discharge (ESD) can damage electronic components. To prevent damage to any printed circuit boards (PCBs), it is important to handle them very carefully. The following measures are generally sufficient to protect your equipment from ESD discharge.

##### Precautions

- Use a grounded wrist strap designed to prevent static discharge.
- Touch a grounded metal object before removing any board from its antistatic bag.
- Handle a board by its edges only; do not touch its components, peripheral chips, memory modules or gold contacts.
- When handling chips or modules, avoid touching their pins.
- Put the serverboard, add-on cards and peripherals back into their antistatic bags when not in use.
- For grounding purposes, make sure your computer chassis provides excellent conductivity between the power supply, the case, the mounting fasteners and the serverboard.

##### Unpacking

The serverboard is shipped in antistatic packaging to avoid static damage. When unpacking the board, make sure the person handling it is static protected.

**Figure 6-1. Chassis Front View**

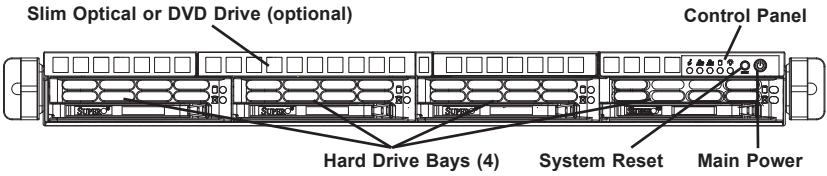

**Figure 6-2. Chassis Rear View**



**Power Supply Modules\*      I/O Ports**

\*The 6018R-MT includes a single power supply module only.

## 6-2 Control Panel

The control panel (located on the front of the chassis) must be connected to the JF1 connector on the serverboard to provide you with system control buttons and status indicators. These wires have been bundled together in a ribbon cable to simplify the connection.

The LEDs inform you of system status. See Chapter 3 for details on the LEDs and the control panel buttons. Details on JF1 can be found in Chapter 5.

## 6-3 System Fans

Four 4-cm high-performance fans provide the cooling for the SuperServer 6018R-MT/6018R-MTR. The chassis includes air seals under the fans and at the chassis cross section, which separates the drive bay area from the serverboard area of the chassis to promote better airflow. It is highly important that the air seal is properly installed and making a good seal in order for the cooling air to circulate properly through the chassis.

The fans can adjust their speed according to the heat level sensed in the system, which results in more efficient and quieter fan operation. Fan speed is controlled by IPMI.

### System Fan Failure

If a fan fails, you will need to have it replaced with the same type. Contact your vendor or Supermicro for information on replacement fans.

## 6-4 Drive Bay Installation/Removal

### Removing the Front Bezel

If your system has a front bezel (optional) attached to the chassis, you must first remove it to gain access to the drive bays. To remove the bezel, first unlock the front of the chassis then press the release knob (see Figure 6-3). Carefully remove the bezel with both hands. A filter located within the bezel can be removed for replacement/cleaning. It is recommended that you keep a maintenance log of filter cleaning/replacement, since its condition will affect the airflow throughout the whole system.

Figure 6-3. Removing the Front Bezel

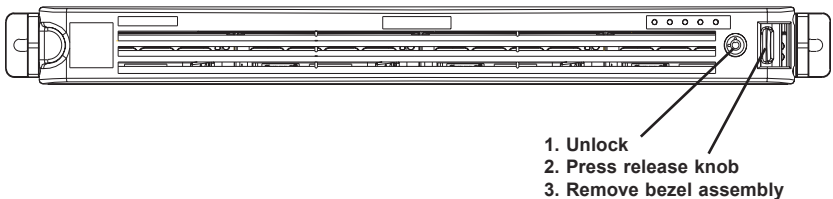

## Accessing the Drive Bays

**SATA Drives:** Because of their hot swap capability, you do not need to access the inside of the chassis or power down the system to install or replace SAS/SATA drives. Proceed to the next step for instructions.

**DVD-ROM Drive (optional):** For installing/removing a DVD-ROM drive, you will need to gain access to the inside of the server by removing the top cover of the chassis. Proceed to the "DVD-ROM Drive Installation" section in this chapter for instructions. Note that only a "slim" DVD-ROM drive will fit into the 6018R-MT/6018R-MTR.

**Warning!** Enterprise level hard disk drives are recommended for use in Supermicro chassis and servers. For information on recommended HDDs, visit the Supermicro Web site at <http://www.supermicro.com/products/nfo/files/storage/SAS-1-ComplList-110909.pdf>

## SATA Drive Installation

### *Mounting a Drive in a Drive Carrier*

The SATA drives are mounted in drive carriers to simplify their installation and removal from the chassis. These carriers also help promote proper airflow for the system. For this reason, even empty carriers without drives installed must remain in the chassis.

1. Install a new drive into the carrier with the printed circuit board side facing down so that the mounting holes align with those in the carrier.
2. Secure the drive to the carrier with six screws, as shown in Figure 6-4.

### *Installing/Removing SATA Drives*

1. To remove a carrier, push the release button located beside the drive LEDs.
2. Swing the colored handle fully out and use it to pull the unit straight out (see Figure 6-5).

**Warning!** Use caution when working around the backplane. Do not touch the backplane with any metal objects and make sure no ribbon cables touch the backplane. Also, regardless of how many drives are installed, all four drive carriers must remain in the chassis to maintain proper airflow.

Figure 6-4. Mounting a Drive in a Carrier

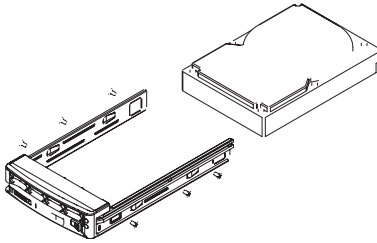

## SATA Backplane

The SATA drives plug into a backplane that provides power, drive ID and bus termination.

Figure 6-5. Removing a Drive from the Server

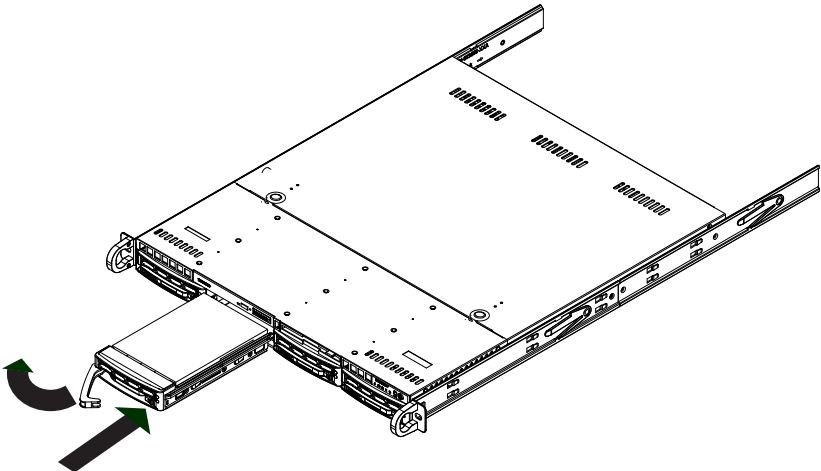

## DVD-ROM Drive Installation (Optional)

The top cover of the chassis must be opened to gain full access to the DVD-ROM drive bay. The 6018R-MT/6018R-MTR accommodates only slim DVD-ROM drives. Side mounting brackets are needed to mount a slim DVD-ROM drive into the 6018R-MT/6018R-MTR server. You must power down the system before installing or removing a DVD-ROM drive.

### ***Removing the Chassis Cover***

1. Grasp the two handles on either side and pull the unit straight out until it locks (you will hear a "click").
2. Depress the two buttons on the top of the chassis to release the top cover and at the same time, push the cover away from you until it stops. You can then lift the top cover from the chassis to gain full access to the inside of the server.

### ***Removing/Installing a Drive***

1. With the chassis cover removed, unplug the power and data cables from the drive.
2. Locate the locking tab at the rear of the drive. It will be on the left side of the drive when viewed from the front of the chassis.
3. Pull the tab away from the drive and push the drive unit out the front of the chassis.
4. Add a new drive by following this procedure in reverse order. You may hear a faint \*click\* of the locking tab when the drive is fully inserted.
5. Remember to reconnect the data and power cables to the drive before replacing the chassis cover and restoring power to the system.



## 6-5 Power Supply

### 6018R-MT

The SuperServer 6018R-MT has a single 440/480W power supply (PWS-441P-1H). This power supply has the capability of operating with an input voltage of 100-240V.

### Power Supply Failure

If the power supply unit fails, the system will shut down and you will need to replace the power supply unit. Replacement units can be ordered directly from Supermicro (see contact information in Chapter 1).

#### *Replacing the Power Supply*

1. First turn the power switch on the control panel off, then unplug the power cord from the system. Replace with the same model, which can be ordered directly from Supermicro.
2. Detach the wiring from the power supply.
3. Remove the screws that secure the power supply to the chassis then pull the module straight out.
4. Carefully insert the new power supply into the open bay and push it completely into the system.
5. Reconnect the power supply wiring.
6. Secure it to the chassis with the screw you removed previously, then reconnect the AC power cord and press the power button on the control panel to restart the system.

## **6018R-MTR**

The SuperServer 6018R-MTR has a 400 watt redundant power supply consisting of two power modules (PWS-406P-1R). Each power supply module has an auto-switching capability, which enables it to automatically sense and operate with an input voltage of 100-240V.

### **Power Supply Failure**

If either of the two power supply modules fail, the other module will take the full load and allow the system to continue operation without interruption. The Power LED will illuminate and remain on until the failed unit has been replaced. Replacement units can be ordered directly from Supermicro. The power supply units have a hot-swap capability, meaning you can replace the failed unit without powering down the system.

#### ***Replacing the Power Supply***

1. First unplug the AC power cord from the failed power supply module.
2. To remove the failed power unit, push its release tab to the side to unlock it, then pull the power supply straight out of the chassis.
3. Replace the failed unit with another unit with another of the same part number (the exact same power supply).
4. Carefully insert the new unit into position in the chassis and push it in until fully seated.
5. Reconnect the power cord to the new power supply.

## Chapter 7

### BIOS

#### 7-1 Introduction

This chapter describes the AMI BIOS setup utility for the X10DRL-i. The ROM BIOS is stored in a Flash EEPROM and can be easily updated. This chapter describes the basic navigation of the AMI BIOS setup utility screens.

**Note:** For AMI BIOS recovery, please refer to the UEFI BIOS Recovery Instructions in Appendix C.

#### Starting BIOS Setup Utility

To enter the AMI BIOS setup utility screens, press the <Delete> key while the system is booting up.

**Note:** In most cases, the <Delete> key is used to invoke the AMI BIOS setup screen. There are a few cases when other keys are used, such as <F1>, <F2>, etc.

Each main BIOS menu option is described in this manual. The AMI BIOS setup menu screen has two main frames. The left frame displays all the options that can be configured. Grayed-out options cannot be configured. Options in blue can be configured by the user. The right frame displays the key legend. Above the key legend is an area reserved for a text message. When an option is selected in the left frame, it is highlighted in white. Often a text message will accompany it.

**Note:** the AMI BIOS has default text messages built in. Supermicro retains the option to include, omit, or change any of these text messages.

The AMI BIOS setup utility uses a key-based navigation system called "hot keys." Most of the AMI BIOS setup utility "hot keys" can be used at any time during the setup navigation process. These keys include <F1>, <F4>, <Enter>, <Esc>, arrow keys, etc.

**Note:** Options printed in **Bold** are default settings.

#### How To Change the Configuration Data

The configuration data that determines the system parameters may be changed by entering the AMI BIOS setup utility. This setup utility can be accessed by pressing <Del> at the appropriate time during system boot.

## How to Start the Setup Utility

Normally, the only visible Power-On Self-Test (POST) routine is the memory test. As the memory is being tested, press the <Delete> key to enter the main menu of the AMI BIOS setup utility. From the main menu, you can access the other setup screens. An AMI BIOS identification string is displayed at the left bottom corner of the screen, below the copyright message.

**Warning:** Do not upgrade the BIOS unless your system has a BIOS-related issue. Flashing the wrong BIOS can cause irreparable damage to the system. In no event shall Supermicro be liable for direct, indirect, special, incidental, or consequential damages arising from a BIOS update. If you have to update the BIOS, do not shut down or reset the system while the BIOS is updating to avoid possible boot failure.

## 7-2 Main Setup

When you first enter the AMI BIOS setup utility, you will enter the Main setup screen. You can always return to the Main setup screen by selecting the Main tab on the top of the screen. The Main BIOS setup screen is shown below.

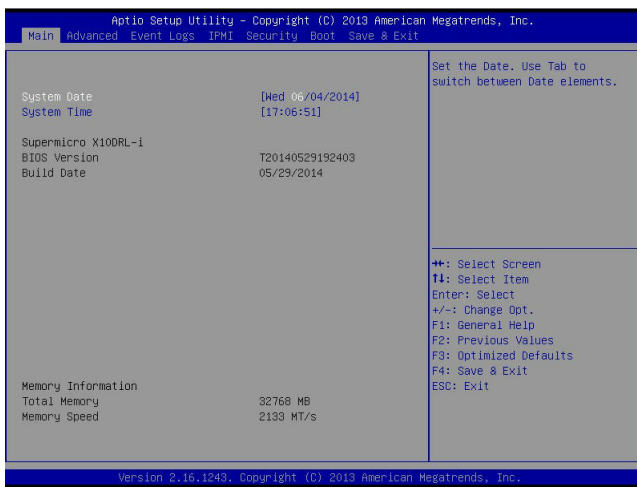

The following Main menu items will be displayed:

**System Date/System Time**

Use this option to change the system date and time. Highlight *System Date* or *System Time* using the arrow keys. Enter new values using the keyboard. Press the <Tab> key or the arrow keys to move between fields. The date must be entered in Day MM/DD/YYYY format. The time is entered in HH:MM:SS format.

**Note:** The time is in the 24-hour format. For example, 5:30 P.M. appears as 17:30:00.

**Supermicro X10DRL-i**

**Version:** This item displays the version of the BIOS ROM used in the system.

**Build Date:** This item displays the date when the version of the BIOS ROM used in the system was built.

**Memory Information**

**Total Memory:** This item displays the total size of memory available in the system.

**Memory Speed:** This item displays the default speed of the memory modules installed in the system.

## 7-3 Advanced Setup Configurations

Use the arrow keys to select Advanced setup and press <Enter> to access the submenu items:

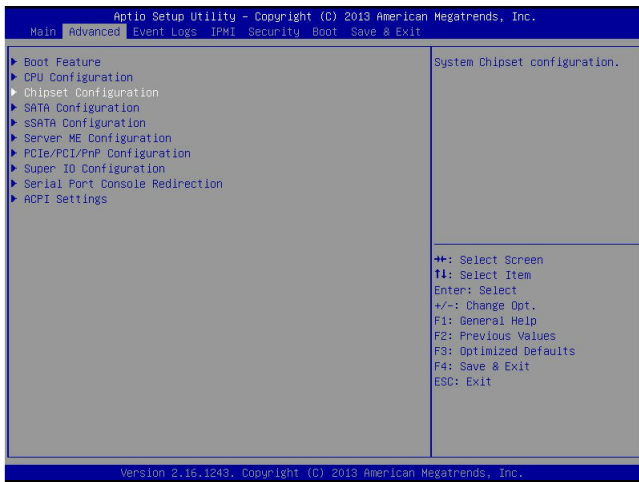

**Warning:** Take Caution when changing the Advanced settings. An incorrect value, a very high DRAM frequency or an incorrect BIOS timing setting may cause the system to malfunction. When this occurs, restore the setting to the manufacture default setting.

### ▶ Boot Feature

#### Quiet Boot

Use this feature to select the screen display between POST messages or the OEM logo at bootup. Select Disabled to display the POST messages. Select Enabled to display the OEM logo instead of the normal POST messages. The options are **Enabled** and Disabled.

#### AddOn ROM Display Mode

Use this item to set the display mode for the Option ROM. Select Keep Current to use the current AddOn ROM display setting. Select Force BIOS to use the Option ROM display mode set by the system BIOS. The options are **Force BIOS** and Keep Current.

#### Bootup Num-Lock State

Use this feature to set the Power-on state for the Numlock key. The options are Off and **On**.

### **Wait For 'F1' If Error**

Select Enabled to force the system to wait until the 'F1' key is pressed if an error occurs. The options are Disabled and **Enabled**.

### **INT19 (Interrupt 19) Trap Response**

Interrupt 19 is the software interrupt that handles the boot disk function. When this item is set to Immediate, the ROM BIOS of the host adaptors will "capture" Interrupt 19 at bootup immediately and allow the drives that are attached to these host adaptors to function as bootable disks. If this item is set to Postponed, the ROM BIOS of the host adaptors will not capture Interrupt 19 immediately and allow the drives attached to these adaptors to function as bootable devices at bootup. The options are **Immediate** and Postponed.

### **Re-try Boot**

When EFI Boot is selected, the system BIOS will automatically reboot the system from an EFI boot device after its initial boot failure. Select Legacy Boot to allow the BIOS to automatically reboot the system from a Legacy boot device after its initial boot failure. The options are **Disabled**, Legacy Boot, and EFI Boot.

## **Power Configuration**

### **Watch Dog Function**

Select Enabled to allow the Watch Dog timer to reboot the system when it is inactive for more than 5 minutes. The options are Enabled and **Disabled**.

### **Power Button Function**

This feature controls how the system shuts down when the power button is pressed. Select 4 Seconds Override for the user to power off the system after pressing and holding the power button for 4 seconds or longer. Select Instant Off to instantly power off the system as soon as the user presses the power button. The options are 4 Seconds Override and **Instant Off**.

### **Restore on AC Power Loss**

Use this feature to set the power state after a power outage. Select Power-Off for the system power to remain off after a power loss. Select Power-On for the system power to be turned on after a power loss. Select Last State to allow the system to resume its last power state before a power loss. The options are Power-On, Stay-Off and **Last State**.

## ►CPU Configuration

This submenu displays the following CPU information as detected by the BIOS. It also allows the user to configure CPU settings.

### ►Processor 1/Processor 2

This submenu displays the following information of the CPU installed in Socket 1 and Socket 2.

- Processor Socket
- Processor ID
- Processor Frequency
- Processor Max Ratio
- Processor Min Ratio
- Microcode Revision
- L1 Cache RAM
- L2 Cache RAM
- L3 Cache RAM
- CPU 1 Version
- CPU 2 Version

### Clock Spread Spectrum

Select Enabled to allow the BIOS to monitor and attempt to reduce the level of Electromagnetic Interference caused by the components whenever needed. The options are **Disabled** and Enabled.

### Hyper-Threading (All)

Select Enable to support Intel's Hyper-threading Technology to enhance CPU performance. The options are **Enable** and Disable.

### Execute-Disable Bit (Available if supported by the OS & the CPU)

Select Enable for Execute Disable Bit Technology support, which will allow the processor to designate areas in the system memory where an application code can execute and where it cannot, thus preventing a worm or a virus from flooding illegal

---



codes to overwhelm the processor to damage the system during an attack. This feature is used in conjunction with the items: "Clear MCA," "VMX," "Enable SMX," and "Lock Chipset" for Virtualization media support. The options are **Enable** and **Disable**. (Refer to Intel and Microsoft websites for more information.)

### **PPIN Control**

Select **Unlock/Enable** to use the Protected-Processor Inventory Number (PPIN) in the system. The options are **Unlock/Enable** and **Unlock/Disable**.

### **Hardware Prefetcher (Available when supported by the CPU)**

If set to **Enable**, the hardware prefetcher will prefetch streams of data and instructions from the main memory to the L2 cache to improve CPU performance. The options are **Disable** and **Enable**.

### **Adjacent Cache Line Prefetch (Available when supported by the CPU)**

Select **Enable** for the CPU to prefetch both cache lines for 128 bytes as comprised. Select **Disable** for the CPU to prefetch both cache lines for 64 bytes. The options are **Disable** and **Enable**.

**Note:** Please reboot the system for changes on this setting to take effect. Please refer to Intel's website for detailed information.

### **DCU (Data Cache Unit) Streamer Prefetcher (Available when supported by the CPU)**

If set to **Enable**, the DCU Streamer Prefetcher will prefetch data streams from the cache memory to the DCU (Data Cache Unit) to speed up data accessing and processing to enhance CPU performance. The options are **Disable** and **Enable**.

### **DCU IP Prefetcher**

If set to **Enable**, the IP prefetcher in the DCU (Data Cache Unit) will prefetch IP addresses to improve network connectivity and system performance. The options are **Enable** and **Disable**.

### **DCU Mode**

Use this feature to set the data-prefecting mode for the DCU (Data Cache Unit). The options are **32KB 8Way Without ECC** and **16KB 4Way With ECC**.

### **Direct Cache Access (DCA)**

Select **Enable** to use Intel DCA (Direct Cache Access) Technology to improve the efficiency of data transferring and accessing. The options are **Auto**, **Enable**, and **Disable**.

### DCA Prefetch Delay

A DCA Prefetcher is used with a TOE (TCP/IP Offload Engine) adapter to prefetch data in order to shorten execution cycles and maximize data processing efficiency. Prefetching data too frequently can saturate the cache directory and delay necessary cache access. This feature reduces or increases the frequency the system prefetches data. The options are [8], [16], **[32]**, [40], [48], [56], [64], [72], [80], [88], [96], [104], [112].

### X2 APIC (Advanced Programmable Interrupt Controller)

Based on Intel's Hyper-Threading architecture, each logical processor (thread) is assigned 256 APIC IDs (APIDs) in 8-bit bandwidth. When this feature is set to Enable, the APIC ID will be expanded (X2) from 8 bits to 16 bits to provide 512 APIDs to each thread to enhance CPU performance. The options are **Disable** and Enable.

### AES-NI

Select Enable to use the Intel Advanced Encryption Standard (AES) New Instructions (NI) to ensure data security. The options are Enable and **Disable**.

### Intel Virtualization Technology

Select Enable to use Intel Virtualization Technology support for Direct I/O VT-d support by reporting the I/O device assignments to the VMM (Virtual Machine Monitor) through the DMAR ACPI tables. This feature offers fully-protected I/O resource sharing across Intel platforms, providing greater reliability, security and availability in networking and data-sharing. The options are **Enable** and Disable

## ► Advanced Power Management Configuration

### Advanced Power Management Configuration

#### Power Technology

Select Energy Efficient to support power-saving mode. Select Custom to customize system power settings. Select Max Performance to optimize system performance. Select Disabled to disable power-saving settings. The options are Disable, **Energy Efficient**, and Custom.

If the option is set to Energy Efficient or Custom, the following items will display:

#### Config TDP (Configuring Thermal Design Power)

Select Enable to configure TDP power settings to enhance thermal management. The options are Enable and **Disable**.

#### Config TDP Level (Available when Config TDP above is set to Enable)

Use this item to set TDP configuration level to enhance thermal management. The options are **Nominal**, Level 1, and Level 2.

---

---

## ► CPU P State Control (Available when Power Technology is set to Custom)

### EIST (P-states)

EIST (Enhanced Intel SpeedStep Technology) allows the system to automatically adjust processor voltage and core frequency to reduce power consumption and heat dissipation. The options are Disable and **Enable**.

### Turbo Mode

Select Enabled to use the Turbo Mode to boost system performance. The options are **Enable** and Disable.

### P-state Coordination

This feature is used to change the P-state (Power-Performance State) coordination type. P-state is also known as "SpeedStep" for Intel processors. Select HW\_ALL to change the P-state coordination type for hardware components only. Select SW\_ALL to change the P-state coordination type for all software installed in the system. Select SW\_ANY to change the P-state coordination type for a software program in the system. The options are **HW\_All**, SW\_ALL, and SW\_ANY.

## ► CPU C State Control (Available when Power Technology is set to Custom)

### Package C State limit

Use this item to set the limit on the C-State package register. The options are C0/1 state, C2 state, C6 (non-Retention) state, and **C6 (Retention) state**.

### CPU C3 Report

Select Enable to allow the BIOS to report the CPU C3 State (ACPI C2) to the operating system. During the CPU C3 State, the CPU clock generator is turned off. The options are Enable and **Disable**.

### CPU C6 Report (Available when Power Technology is set to Custom)

Select Enable to allow the BIOS to report the CPU C6 state (ACPI C3) to the operating system. During the CPU C6 state, power to all cache is turned off. The options are **Enable** and Disable.

### Enhanced Halt State (C1E)

Select Enabled to use Enhanced Halt-State technology, which will significantly reduce the CPU's power consumption by reducing the CPU's clock cycle and voltage during a Halt-state. The options are Disable and **Enable**.

## ► CPU T State Control (Available when Power Technology is set to Custom)

### ACPI (Advanced Configuration Power Interface) T-States

Select Enable to support CPU throttling by the operating system to reduce power consumption. The options are **Enable** and Disable.

### FAST\_RAPL\_NSTRIKE\_PL2\_DUTY\_CYCLE

This feature displays the value of the item above within the range between 25 (10%) and 64 (25%). The default setting is **64**.

### Turbo Power Limit Lock

Select Enable to set the power use limit for the machine when it is running in the turbo mode. The options are Enable and **Disable**.

### Long Power Limit Override

Select Enable to support long-term power limit override. If this feature is disabled, BIOS will set the default value. The options are **Enable** and Disable.

### Long Duration Power Limit

This item displays the power limit set by the user during which long duration power is maintained. The default setting is **0**.

### Package Clamping Limit1

Use this item to set the limit on power performance states for the runtime processor, with P0 being the state with the highest frequency (clock speed) and power (consumption), and P1, a step lower in performance than P0, with its frequency and voltage scaled back a notch. The options are Between P1/P0 and **Below P1**.

### Short Duration Power Limit Enable

Select Enable to support Short Duration Power Limit (Power Limit 2). The options are **Enable** and Disable.

### Short Duration Power Limit

This item displays the time period during which short duration power is maintained. The default setting is **0**.

### Package Clamping Limit2

Use this item to set the limit on power performance states for the processor operating in turbo mode, with P0 being the state with the highest frequency (clock speed) and power (consumption), and P1, a step lower in performance

---

than P0, with its frequency and voltage scaled back a notch. The options are Between P1/P0 and **Below P1**.

## ► Chipset Configuration

**Warning!** Please set the correct settings for the items below. A wrong configuration setting may cause the system to become malfunction.

### ► North Bridge

This feature allows the user to configure the settings for the Intel North Bridge.

### ► IIO Configuration

#### **EV DFX (Device Function On-Hide) Feature**

When this feature is set to Enable, the EV\_DFX Lock Bits that are located on a processor will always remain clear during electric tuning. The options are **Disable** and Enable.

### ► IIO1 Configuration

#### **CPU1 SLOT2 PCI-E 3.0 X8**

This item configures the PCI-E port Bifurcation setting for a PCI-E port specified by the user. The options are Gen 1 (2.5GT/s), Gen 2 (5 GT/s), and **Gen 3 (8GT/s)**.

#### **CPU1 SLOT3 PCI-E 3.0 X8**

This item configures the PCI-E port Bifurcation setting for a PCI-E port specified by the user. The options are Gen 1 (2.5GT/s), Gen 2 (5 GT/s), and **Gen 3 (8GT/s)**.

#### **CPU1 SLOT6 PCI-E 3.0 X8**

This item configures the PCI-E port Bifurcation setting for a PCI-E port specified by the user. The options are Gen 1 (2.5GT/s), Gen 2 (5 GT/s), and **Gen 3 (8GT/s)**.

#### **CPU1 SLOT5 PCI-E 3.0 X16**

This item configures the PCI-E port Bifurcation setting for a PCI-E port specified by the user. The options are Gen 1 (2.5GT/s), Gen 2 (5 GT/s), and **Gen 3 (8GT/s)**.

### ► IIO2 Configuration

#### **CPU2 SLOT4 PCI-E 3.0 X4 (IN X8)**

This item configures the PCI-E port Bifurcation setting for a PCI-E port specified by the user. The options are Gen 1 (2.5GT/s), Gen 2 (5 GT/s), and **Gen 3 (8GT/s)**.

---

## ► IOAT (Intel® IO Acceleration) Configuration

### Enable IOAT

Select Enable to enable Intel I/OAT (I/O Acceleration Technology) support, which significantly reduces CPU overhead by leveraging CPU architectural improvements and freeing the system resource for other tasks. The options are **Enable** and **Disable**.

### No Snoop

Select Enable to support no-snoop mode for each CB device. The options are **Disable** and **Enable**.

### Relaxed Ordering

Select Enable to enable Relaxed Ordering support which will allow certain transactions to violate the strict-ordering rules of PCI bus for a transaction to be completed prior to other transactions that have already been enqueued. The options are **Disable** and **Enable**.

## ► Intel VT for Directed I/O (VT-d)

### Intel VT for Direct I/O (VT-d)

#### Intel® VT for Directed I/O (VT-d)

Select Enable to use Intel Virtualization Technology support for Direct I/O VT-d support by reporting the I/O device assignments to the VMM (Virtual Machine Monitor) through the DMAR ACPI Tables. This feature offers fully-protected I/O resource sharing across Intel platforms, providing greater reliability, security and availability in networking and data-sharing. The options are **Enable** and **Disable**.

### Interrupt Remapping

Select Enable for Interrupt Remapping support to enhance system performance. The options are **Enable** and **Disable**.

### Coherency Support (Non-Iscoch)

Select Enable for the Non-Iscoch VT-d engine to pass through DMA (Direct Memory Access) to enhance system performance. The options are **Enable** and **Disable**.

### Coherency Support (Iscoch)

Select Enable for the Iscoch VT-d engine to pass through ATS to enhance system performance. The options are **Enable** and **Disable**.

---

## ► QPI (Quick Path Interconnect) Configuration

### QPI Status

The following information will display:

- Number of CPU
- Number of IIO
- Current QPI Link Speed
- Current QPI Link Frequency
- QPI Global MMIO Low Base/Limit
- QPI Global MMIO High Base/Limit
- QPI PCIe Configuration Base/Size

### Link Speed Mode

Use this item to select the data transfer speed for QPI Link connections. The options are **Fast** and Slow.

### Link Frequency Select

Use this item to select the desired frequency for QPI Link connections. The options are 6.4GB/s, 8.0GB/s, 9.6GB/s, **Auto**, and Auto Limited.

### Link L0p Enable

Select Enable for Link L0p support. The options are **Enable** and Disable.

### Link L1 Enable

Select Enable for Link L1 support. The options are **Enable** and Disable.

### COD Enable (Available when the OS and the CPU support this feature)

Select Enabled for Cluster-On-Die support to enhance system performance in cloud computing. The options are Enable, **Disable**, and Auto.

### Early Snoop (Available when the OS and the CPU support this feature)

Select Enabled for Early Snoop support to enhance system performance. The options are Enable, Disable, and **Auto**.

### **Isoc Mode**

Select Enabled for Isochronous support to meet QoS (Quality of Service) requirements. This feature is especially important for Virtualization Technology. The options are Enable and **Disable**.



---

## ► Memory Configuration

### Enforce POR

Select Enable to enforce POR restrictions on DDR4 frequency and voltage programming. The options are **Enabled** and Disabled.

### Memory Frequency

Use this feature to set the maximum memory frequency for onboard memory modules. The options are **Auto**, 1333, 1400, 1600, 1800, 1867, 2000, 2133, 2200, 2400, 2600, 2667, and Reserved (Do not select Reserved).

### ECC Support

Select Enable to enable Error Checking & Correction (ECC) support for onboard memory modules. The options are **Auto**, Enable and Disable.

### Data Scrambling

Select Enabled to enable data scrambling to enhance system performance and data integrity. The options are **Auto**, Disabled and Enabled.

### Enable ADR

Select Enabled for ADR (Automatic Diagnostic Repository) support to enhance memory performance. The options are Enabled and **Disabled**.

### DRAM RAPL (Running Average Power Limit) Baseline

Use this feature to set the run-time power-limit baseline for DRAM modules. The options are Disable, DRAM RAPL Mode 0, and **DRAM RAPL Mode 1**.

### Set Throttling Mode

Throttling improves reliability and reduces power consumption in the processor via automatic voltage control during processor idle states. The options are Disabled and **CLTT** (Closed Loop Thermal Throttling).

### Socket Interleave Below 4GB

Select Enabled for the memory above the 4G Address space to be split between two sockets. The options are Enable and **Disable**.

### Channel Interleaving

Use this item to set DIMM channel interleaving mood. The options are **Auto**, 1-Way Interleave, 2-Way Interleave, 3-Way Interleave, and 4-Way Interleave.

### Rank Interleaving

Use this item to select a rank memory interleaving method. The options are **Auto**, 1-Way, 2-Way, 4-Way, and 8-Way.

### **A7 Mode**

Select Enabled to support the A7 (Addressing) mode to improve memory performance. The options are **Enable** and Disable.

### **►DIMM Information**

This item displays the status of a DIMM module specified by the user.

- P1-DIMMA1 - P1-DIMMD1
- P2-DIMME1 - P2-DIMMH1

### **►Memory RAS (Reliability\_Availability\_Serviceability) Configuration**

Use this submenu to configure the following Memory RAS settings.

#### **RAS Mode**

When Disable is selected, RAS is not supported. When Mirror is selected, the serverboard maintains two identical copies of all data in memory for data backup. When Lockstep is selected, the serverboard uses two areas of memory to run the same set of operations in parallel to boost performance. The options are **Disable**, Mirror, and Lockstep Mode.

#### **Lockstep x4 DIMMs**

Select Enable to enable Lockstep support for x4 DIMM modules. The options are **Auto**, Disabled, and Enabled.

#### **Memory Rank Sparing**

Select Enable to enable memory-sparing support for memory ranks to improve memory performance. The options are **Disabled** and Enabled.

#### **Patrol Scrub**

Patrol Scrubbing is a process that allows the CPU to correct correctable memory errors detected on a memory module and send the correction to the requestor (the original source). When this item is set to Enabled, the IO hub will read and write back one cache line every 16K cycles, if there is no delay caused by internal processing. By using this method, roughly 64 GB of memory behind the IO hub will be scrubbed every day. The options are **Enable** and Disable.

### Patrol Scrub Interval

This feature allows you to decide how many hours the system should wait before the next complete patrol scrub is performed. Use the keyboard to enter a value from 0-24. The Default setting is **24**.

### Demand Scrub

Demand Scrubbing is a process that allows the CPU to correct correctable memory errors found on a memory module. When the CPU or I/O issues a demand-read command, and the read data from memory turns out to be a correctable error, the error is corrected and sent to the requestor (the original source). Memory is updated as well. Select **Enable** to use Demand Scrubbing for ECC memory correction. The options are **Enable** and **Disable**.

### Device Tagging

Select **Enable** to support device tagging. The options are **Disable** and **Enable**.

## ►South Bridge Configuration

The following South Bridge information will display:

### ►USB Configuration

- USB Module Version
- USB Devices

### Legacy USB Support

Select **Enabled** to support onboard legacy USB devices. Select **Auto** to disable legacy support if there are no legacy USB devices present. Select **Disable** to have all USB devices available for EFI applications only. The options are **Enabled**, **Disabled** and **Auto**.

### XHCI Hand-Off

This is a work-around solution for operating systems that do not support XHCI (Extensible Host Controller Interface) hand-off. The XHCI ownership change should be claimed by the XHCI driver. The settings are **Enabled** and **Disabled**.

### EHCI Hand-Off

This item is for operating systems that do not support Enhanced Host Controller Interface (EHCI) hand-off. When this item is enabled, EHCI ownership change will be claimed by the EHCI driver. The settings are **Enabled** and **Disabled**.

**USB Mass Storage Driver Support**

Select Enabled for USB mass storage device support. The options are Disabled and **Enabled**.

**Port 60/64 Emulation**

Select Enabled for I/O port 60h/64h emulation support, which in turn, will provide complete legacy USB keyboard support for the operating systems that do not support legacy USB devices. The options are Disabled and **Enabled**.

**USB 3.0 Support**

Select Enabled for USB 3.0 support. The options are Smart Auto, **Auto**, Enabled, Disabled and Manual.

**EHCI1**

Select Enabled to enable EHCI (Enhanced Host Controller Interface) support on USB 2.0 connector #1 (-at least one USB 2.0 connector should be enabled for EHCI support.) The options are Disabled and **Enabled**.

**EHCI2**

Select Enabled to enable EHCI (Enhanced Host Controller Interface) support on USB 2.0 connector #2 (-at least one USB 2.0 connector should be enabled for EHCI support.) The options are Disabled and **Enabled**.

**XHCI Pre-Boot Drive**

Select Enabled to enable XHCI (Extensible Host Controller Interface) support on a pre-boot drive specified by the user. The options are Enabled and **Disabled**.

**XHCI Idle L1**

Select Enabled for XHCI (Extensible Host Controller Interface) Idle Level 1 support on a USB 3.0 connector specified by the user. The options are **Enabled** and Disabled.

**PCH DMI ASPM**

Select Enabled to enable ASPM (Active State Power Management) support for a PCH DMI drive. The options are **Disabled** and Enabled.

## ►SATA Configuration

When this submenu is selected, AMI BIOS automatically detects the presence of the SATA devices that are supported by the Intel PCH chip and displays the following items:

### SATA Controller

This item enables or disables the onboard SATA controller supported by the Intel PCH chip. The options are **Enabled** and Disabled.

### Configure SATA as

Select IDE to configure a SATA drive specified by the user as an IDE drive. Select AHCI to configure a SATA drive specified by the user as an AHCI drive. Select RAID to configure a SATA drive specified by the user as a RAID drive. The options are IDE, **AHCI**, and RAID.

*\*If the item above "Configure SATA as" is set to AHCI, the following items will display:*

### Support Aggressive Link Power Management

When this item is set to Enabled, the SATA AHCI controller manages the power usage of the SATA link. The controller will put the link to a low power state when the I/O is inactive for an extended period of time, and the power state will return to normal when the I/O becomes active. The options are **Enabled** and Disabled.

### SATA Port 0~ Port 5

This item displays the information detected on the installed SATA drive on the particular SATA port.

- Model number of drive and capacity
- Software Preserve Support

### Port 0~ Port 5

Select Enabled to enable a SATA port specified by the user. The options are Disabled and Enabled.

### Port 0 ~ Port 5 Hot Plug

Select Enabled to enable hot-plugging support for a port specified by the user, which will allow the user to replace a SATA disk drive installed on this port without shutting down the system. The options are **Enabled** and Disabled.

### Port 0 ~ Port 5 Spin Up Device

On an edge detect from 0 to 1, set this item to allow the PCH to initialize the device. The options are Enabled and **Disabled**.

**Port 0 ~ Port 5 SATA Device Type**

Use this item to specify if the SATA port specified by the user should be connected to a Solid State drive or a Hard Disk Drive. The options are Hard Disk Drive and Solid State Drive.

*\*If the item above "Configure SATA as" is set to IDE, the following items will display:*

**Serial ATA Port 0~ Port 5**

This item indicates that a SATA port specified by the user is installed (present) or not.

**Port 0 ~ Port 5 SATA Device Type (Available when a SATA port is detected)**

Use this item to specify if the SATA port specified by the user should be connected to a Solid State drive or a Hard Disk Drive. The options are Hard Disk Drive and Solid State Drive.

*\*If the item above "Configure SATA as" is set to RAID, the following items will display:*

**Support Aggressive Link Power Management**

When this item is set to Enabled, the SATA AHCI controller manages the power usage of the SATA link. The controller will put the link to a low power state when the I/O is inactive for an extended period of time, and the power state will return to normal when the I/O becomes active. The options are **Enabled** and Disabled.

**SATA RAID Option ROM/UEFI Driver**

Select EFI to load the EFI driver for system boot. Select Legacy to load a legacy driver for system boot. The options are Disabled, EFI, and **Legacy**.

**Serial ATA Port 0~ Port 5**

This item displays the information detected on the installed SATA drives on the particular SATA port.

- Model number of drive and capacity
- Software Preserve Support

**Port 0~ Port 5**

Select Enabled to enable a SATA port specified by the user. The options are Disabled and **Enabled**.

**Port 0 ~ Port 5 Hot Plug**

Select Enabled to enable hot-plugging support for a port specified by the user, which will allow the user to replace a SATA disk drive installed on this port without shutting down the system. The options are Enabled and **Disabled**.

**Port 0 ~ Port 5 Spin Up Device**

On an edge detect from 0 to 1, set this item to allow the PCH to start a COMRESET initialization to the device. The options are Enabled and **Disabled**.

**Port 0 ~ Port 5 SATA Device Type**

Use this item to specify if the SATA port specified by the user should be connected to a Solid State drive or a Hard Disk Drive. The options are Hard Disk Drive and Solid State Drive.

**►sSATA Configuration**

When this submenu is selected, AMI BIOS automatically detects the presence of the SATA devices that are supported by the PCH-sSATA controller and displays the following items:

**sSATA Controller**

This item enables or disables the onboard SATA controller supported by the Intel PCH-sSATA controller. The options are **Enabled** and Disabled.

**Configure sSATA as**

Select IDE to configure an sSATA drive specified by the user as an IDE drive. Select AHCI to configure an sSATA drive specified by the user as an AHCI drive. Select RAID to configure an sSATA drive specified by the user as a RAID drive. The options are IDE, **AHCI**, and RAID.

*\*If the item above "Configure sSATA as" is set to AHCI, the following items will display:*

**Support Aggressive Link Power Management**

When this item is set to Enabled, the SATA AHCI controller manages the power usage of the SATA link. The controller will put the link to a low power state when the I/O is inactive for an extended period of time, and the power state will return to normal when the I/O becomes active. The options are **Enabled** and Disabled.

**sSATA Port 0~ Port 3**

This item displays the information detected on the installed on the sSATA port. specified by the user.

- Model number of drive and capacity

- Software Preserve Support

### **sSATA Port 0~ Port 3**

Select Enabled to enable an sSATA port specified by the user. The options are Disabled and Enabled.

### **sSATA Port 0 ~ Port 3 Hot Plug**

Select Enabled to enable hot-plugging support for a port specified by the user, which will allow the user to replace a sSATA disk drive installed on this port without shutting down the system. The options are **Enabled** and Disabled.

### **sSATA Port 0 ~ Port 3 Spin Up Device**

On an edge detect from 0 to 1, set this item to allow the PCH to start a COMRE-SET initialization to the device. The options are Enabled and **Disabled**.

### **Port 0 ~ Port 3 sSATA Device Type**

Use this item to specify if the sSATA port specified by the user should be connected to a Solid State drive or a Hard Disk Drive. The options are Hard Disk Drive and Solid State Drive.

*\*If the item above "Configure sSATA as" is set to IDE, the following items will display:*

### **sSATA Port 0~ Port 3**

This item indicates that an sSATA port specified by the user is installed (present) or not.

### **Port 0 ~ Port 3 sSATA Device Type (Available when a SATA port is detected)**

Use this item to specify if the sSATA port specified by the user should be connected to a Solid State drive or a Hard Disk Drive. The options are Hard Disk Drive and Solid State Drive.

*\*If the item above "Configure sSATA as" is set to RAID, the following items will display:*

### **Support Aggressive Link Power Management**

When this item is set to Enabled, the SATA AHCI controller manages the power usage of the SATA link. The controller will put the link to a low power state when the I/O is inactive for an extended period of time, and the power state will return to normal when the I/O becomes active. The options are **Enabled** and Disabled.



**sSATA RAID Option ROM/UEFI Driver**

Select EFI to load the EFI driver for system boot. Select Legacy to load a legacy driver for system boot. The options are Disabled, EFI, and **Legacy**.

**sSATA Port 0~ Port 3**

This item displays the information detected on the installed sSATA drives on the particular sSATA port.

- Model number of drive and capacity
- Software Preserve Support

**sSATA Port 0~ Port 3**

Select Enabled to enable an sSATA port specified by the user. The options are Disabled and Enabled.

**sSATA Port 0 ~ Port 3 Hot Plug**

This feature designates this port for hot plugging. Set this item to Enabled for hot-plugging support, which will allow the user to replace an sSATA drive without shutting down the system. The options are Enabled and **Disabled**.

**sSATA Port 0 ~ Port 3 Spin Up Device**

On an edge detect from 0 to 1, set this item to allow the PCH to start a COMRESET initialization to the device. The options are Enabled and **Disabled**.

**Port 0 ~ Port 3 sSATA Device Type**

Use this item to specify if the sSATA port specified by the user should be connected to a Solid State drive or a Hard Disk Drive. The options are Hard Disk Drive and Solid State Drive.

**► Server ME (Management Engine) Configuration**

This feature displays the following system ME configuration settings.

- General ME Configuration
- Operational Firmware Version
- Recovery Firmware Version
- ME Firmware Features
- ME Firmware Status #1

- ME Firmware Status #2
  - Current State
  - Error Code

## ► PCIe/PCI/PnP Configuration

The following PCI information will be displayed:

- PCI Bus Driver Version

### PCI Latency Timer

Use this item to configure the PCI latency timer for a device installed on a PCI bus. Select 32 to set the PCI latency timer to 32 PCI clock cycles. The options are **32**, 64, 96, 128, 160, 192, 224 and 248 (PCI Bus Clocks).

### PCI-X Latency Timer

Use this item to configure the PCI-X latency timer for a device installed on a PCI -X bus. Select 32 to set the PCI-X latency timer to 32 PCI-X clock cycles. The options are 32, **64**, 96, 128, 160, 192, 224 and 248 (PCI Bus Clocks).

### VGA Palette Snoop

Select Enabled to support VGA palette register snooping which will allow a PCI card that does not contain its own VGA color palette to examine a video card palette and mimic it for proper color display. The options are **Disabled** and Enabled.

### PCI AER (Advanced Error-Reporting) Support

Select Enabled to support Advanced Error-Reporting for onboard PCI devices. The options are **Disabled** and Enabled.

### Above 4G Decoding (Available if the system supports 64-bit PCI decoding)

Select Enabled to decode a PCI device that supports 64-bit in the space above 4G Address. The options are Enabled and **Disabled**.

### SR-IOV (Available if the system supports Single-Root Virtualization)

Select Enabled for Single-Root IO Virtualization support. The options are Enabled and **Disabled**.

---

### Maximum Payload

Select Auto for the system BIOS to automatically set the maximum payload value for a PCI-E device to enhance system performance. The options are **Auto**, 128 Bytes, and 256 Bytes.

### Maximum Read Request

Select Auto for the system BIOS to automatically set the maximum size for a read request for a PCI-E device to enhance system performance. The options are **Auto**, 128 Bytes, 256 Bytes, 512 Bytes, 1024 Bytes, 2048 Bytes, and 4096 Bytes.

### ASPM Support

Use this item to set the Active State Power Management (ASPM) level for a PCI-E device. Select Auto for the system BIOS to automatically set the ASPM level based on the system configuration. Select Disabled to disable ASPM support. The options are **Disabled**, and Auto.

**Warning:** Enabling ASPM support may cause some PCI-E devices to fail!

### MMIOHBase

Use this item to select the base memory size according to memory-address mapping for the IO hub. The base memory size must be between 4032G to 4078G. The options are **56T**, 48T, 24T, 512G, and 256G.

### MMIO High Size

Use this item to select the high memory size according to memory-address mapping for the IO hub. The options are **256G**, 128G, 512G, and 1024G.

### PCH Slot1 PCI-E 2.0 x4 (In x8) (OPROM)/CPU1 Slot2 PCI-E 3.0 x8 (OPROM)/CPU1 Slot3 PCI-E x8 (OPROM)/CPU2 Slot4 PCI-E 3.0 x4 (In x8) (OPROM)/CPU1 Slot5 PCI-E x16 (OPROM)//CPU2 Slot6 PCI-E 3.0x8 (OPROM)

Select Enabled to enable Option ROM support to boot the computer using a device installed on the slot specified by the user. The options are Disabled, **Legacy** and EFI.

### Onboard LAN Option ROM Type

Select Enabled to enable Option ROM support to boot the computer using a device installed on the slot specified by the user. The options are **Legacy** and EFI.

### Onboard LAN1 Option ROM/Onboard LAN2 Option ROM/Onboard Video Option ROM

Use this option to select the type of device installed in LAN Port1, LAN Port2 or the onboard video device used for system boot. The default setting for LAN1 Option ROM is **PXE**, for LAN2 Option ROM is **Disabled** and for Onboard Video Option ROM is **Legacy**.

### VGA Priority

Use this item to select the graphics device to be used as the primary video display for system boot. The options are **Onboard** and Offboard.

### Network Stack

Select Enabled to enable PXE (Preboot Execution Environment) or UEFI (Unified Extensible Firmware Interface) for network stack support. The options are Enabled and **Disabled**.

## ►Super IO Configuration

### Super IO Chip AST2400

#### ►Serial Port 1 Configuration/Serial Port 2 Configuration

##### Serial Port 1/Serial Port 2

Select Enabled to enable the onboard serial port specified by the user. The options are **Enabled** and Disabled.

##### Device Settings

This item displays the base I/O port address and the Interrupt Request address of a serial port specified by the user.

##### Change Port 1 Settings/Change Port 2 Settings

This feature specifies the base I/O port address and the Interrupt Request address of Serial Port 1 or Serial Port 2. Select **Auto** for the BIOS to automatically assign the base I/O and IRQ address to a serial port specified.

The options for Serial Port 1 are **Auto**, (IO=3F8h; IRQ=4), (IO=3F8h; IRQ=3, 4, 5, 6, 7, 9, 10, 11, 12), (IO=2F8h; IRQ=3, 4, 5, 6, 7, 9, 10, 11, 12); (IO=3E8h; IRQ=3, 4, 5, 6, 7, 9, 10, 11, 12), and (IO=2E8h; IRQ=3, 4, 5, 6, 7, 9, 10, 11, 12).

The options for Serial Port 2 are **Auto**, (IO=3F8h; IRQ=4), (IO=3F8h; IRQ=3, 4, 5, 6, 7, 9, 10, 11, 12), (IO=2F8h; IRQ=3, 4, 5, 6, 7, 9, 10, 11, 12); (IO=3E8h; IRQ=3, 4, 5, 6, 7, 9, 10, 11, 12), and (IO=2E8h; IRQ=3, 4, 5, 6, 7, 9, 10, 11, 12).

##### Serial Port 2 Attribute

Select SOL to use COM Port 2 as a Serial\_Over\_LAN (SOL) port for console redirection. The options are COM and **SOL**.

## ► Serial Port Console Redirection

### COM 1

#### COM 1 Console Redirection

Select Enabled to enable COM Port 1 Console Redirection, which will allow a client machine to be connected to a host machine at a remote site for networking. The options are **Disabled** and Enabled.

*\*If the item above set to Enabled, the following items will become available for configuration:*

### ► COM1 Console Redirection Settings

#### Terminal Type

This feature allows the user to select the target terminal emulation type for Console Redirection. Select VT100 to use the ASCII Character set. Select VT100+ to add color and function key support. Select ANSI to use the Extended ASCII Character Set. Select VT-UTF8 to use UTF8 encoding to map Unicode characters into one or more bytes. The options are ANSI, VT100, **VT100+**, and VT-UTF8.

#### Bits Per second

Use this item to set the transmission speed for a serial port used in Console Redirection. Make sure that the same speed is used in the host computer and the client computer. A lower transmission speed may be required for long and busy lines. The options are 9600, 19200, 38400, 57600 and **115200** (bits per second).

#### Data Bits

Use this feature to set the data transmission size for Console Redirection. The options are 7 (Bits) and **8 (Bits)**.

#### Parity

A parity bit can be sent along with regular data bits to detect data transmission errors. Select Even if the parity bit is set to 0, and the number of 1's in data bits is even. Select Odd if the parity bit is set to 0, and the number of 1's in data bits is odd. Select None if you do not want to send a parity bit with your data bits in transmission. Select Mark to add a mark as a parity bit to be sent along with the data bits. Select Space to add a Space as a parity bit to be sent with your data bits. The options are **None**, Even, Odd, Mark and Space.

### Stop Bits

A stop bit indicates the end of a serial data packet. Select 1 Stop Bit for standard serial data communication. Select 2 Stop Bits if slower devices are used. The options are **1** and **2**.

### Flow Control

Use this item to set the flow control for Console Redirection to prevent data loss caused by buffer overflow. Send a "Stop" signal to stop sending data when the receiving buffer is full. Send a "Start" signal to start sending data when the receiving buffer is empty. The options are **None** and Hardware RTS/CTS.

### VT-UTF8 Combo Key Support

Select Enabled to enable VT-UTF8 Combination Key support for ANSI/VT100 terminals. The options are **Enabled** and Disabled.

### Recorder Mode

Select Enabled to capture the data displayed on a terminal and send it as text messages to a remote server. The options are **Disabled** and Enabled.

### Resolution 100x31

Select Enabled for extended-terminal resolution support. The options are Disabled and **Enabled**.

### Legacy OS Redirection Resolution

Use this item to select the number of rows and columns used in Console Redirection for legacy OS support. The options are 80x24 and **80x25**.

### Putty KeyPad

This feature selects Function Keys and KeyPad settings for Putty, which is a terminal emulator designed for the Windows OS. The options are **VT100**, LINUX, XTERMR6, SCO, ESCN, and VT400.

### Redirection After BIOS Post

Use this feature to enable or disable legacy Console Redirection after BIOS POST. When the option-Bootloader is selected, legacy Console Redirection is disabled before booting the OS. When the option- Always Enable is selected, legacy Console Redirection remains enabled upon OS bootup. The options are **Always Enable** and Bootloader.

---

## SOL/COM2

### Console Redirection

Select Enabled to use the SOL port for Console Redirection. The options are **Enabled** and Disabled.

*\*If the item above set to Enabled, the following items will become available for user's configuration:*

## ► SOL/COM2 Console Redirection Settings

Use this feature to specify how the host computer will exchange data with the client computer, which is the remote computer used by the user.

### Terminal Type

Use this feature to select the target terminal emulation type for Console Redirection. Select VT100 to use the ASCII Character set. Select VT100+ to add color and function key support. Select ANSI to use the Extended ASCII Character Set. Select VT-UTF8 to use UTF8 encoding to map Unicode characters into one or more bytes. The options are ANSI, VT100, **VT100+**, and VT-UTF8.

### Bits Per second

Use this feature to set the transmission speed for a serial port used in Console Redirection. Make sure that the same speed is used in the host computer and the client computer. A lower transmission speed may be required for long and busy lines. The options are 9600, 19200, 38400, 57600 and **115200** (bits per second).

### Data Bits

Use this feature to set the data transmission size for Console Redirection. The options are 7 (Bits) and **8 (Bits)**.

### Parity

A parity bit can be sent along with regular data bits to detect data transmission errors. Select Even if the parity bit is set to 0, and the number of 1's in data bits is even. Select Odd if the parity bit is set to 0, and the number of 1's in data bits is odd. Select None if you do not want to send a parity bit with your data bits in transmission. Select Mark to add a mark as a parity bit to be sent along with the data bits. Select Space to add a Space as a parity bit to be sent with your data bits. The options are **None**, Even, Odd, Mark and Space.

### Stop Bits

A stop bit indicates the end of a serial data packet. Select 1 Stop Bit for standard serial data communication. Select 2 Stop Bits if slower devices are used. The options are **1** and 2.

### Flow Control

Use this feature to set the flow control for Console Redirection to prevent data loss caused by buffer overflow. Send a "Stop" signal to stop sending data when the receiving buffer is full. Send a "Start" signal to start data-sending when the receiving buffer is empty. The options are **None** and Hardware RTS/CTS.

### VT-UTF8 Combo Key Support

Select Enabled to enable VT-UTF8 Combination Key support for ANSI/VT100 terminals. The options are **Enabled** and Disabled.

### Recorder Mode

Select Enabled to capture the data displayed on a terminal and send it as text messages to a remote server. The options are **Disabled** and Enabled.

### Resolution 100x31

Select Enabled for extended-terminal resolution support. The options are Disabled and **Enabled**.

### Legacy OS Redirection Resolution

Use this feature to select the number of rows and columns used in Console Redirection for legacy OS support. The options are 80x24 and **80x25**.

### Putty KeyPad

This feature selects Function Keys and KeyPad settings for Putty, which is a terminal emulator designed for the Windows OS. The options are **VT100**, LINUX, XTERMR6, SCO, ESCN, and VT400.

### Redirection After BIOS Post

Use this feature to enable or disable legacy Console Redirection after BIOS POST (Power-On Self-Test). When this feature is set to Bootloader, legacy Console Redirection is disabled before booting the OS. When this feature is set to Always Enable, legacy Console Redirection remains enabled upon OS boot. The options are **Always Enable** and Bootloader.

### Serial Port for Out-of-Band Management/Windows Emergency Management Services (EMS)

The submenu allows the user to configure Console Redirection settings to support Out-of-Band Serial Port management.

### Console Redirection

Select Enabled to use a COM port selected by the user for EMS Console Redirection. The options are Enabled and **Disabled**.



*\*If the item above set to Enabled, the following items will become available for user's configuration:*

### **Out-of-Band Management Port**

The feature selects a serial port in a client server to be used by the Windows Emergency Management Services (EMS) to communicate with a remote host server. The options are **COM1 (Console Redirection)** and COM2/SOL (Console Redirection).

### **Terminal Type**

Use this feature to select the target terminal emulation type for Console Redirection. Select VT100 to use the ASCII character set. Select VT100+ to add color and function key support. Select ANSI to use the extended ASCII character set. Select VT-UTF8 to use UTF8 encoding to map Unicode characters into one or more bytes. The options are ANSI, VT100, VT100+, and **VT-UTF8**.

### **Bits Per Second**

This item sets the transmission speed for a serial port used in Console Redirection. Make sure that the same speed is used in both host computer and the client computer. A lower transmission speed may be required for long and busy lines. The options are 9600, 19200, 57600, and **115200** (bits per second).

### **Flow Control**

Use this item to set the flow control for Console Redirection to prevent data loss caused by buffer overflow. Send a "Stop" signal to stop data-sending when the receiving buffer is full. Send a "Start" signal to start data-sending when the receiving buffer is empty. The options are **None**, Hardware RTS/CTS, and Software Xon/Xoff.

The setting for each these features is displayed:

### **Data Bits, Parity, Stop Bits**

## ► Trusted Computing (Available when a TPM device is installed and detected by the BIOS)

### Configuration

#### Security Device Support

If this feature and the TPM jumper on the serverboard are both set to Enabled, onboard security devices will be enabled for TPM (Trusted Platform Module) support to enhance data integrity and network security. Please reboot the system for a change on this setting to take effect. The options are Enabled and **Disabled**.

#### TPM State

Select Enabled to use TPM (Trusted Platform Module) settings to enhance system data security. Please reboot your system for any change on the TPM state to take effect. The options are Disabled and **Enabled**.

#### Pending Operation

Use this item to schedule a TPM-related operation to be performed by a security device for system data integrity. Your system will reboot to carry out a pending TPM operation. The options are **0**, Enable Take Ownership, Disable Take Ownership, and TPM Clear.

**Note:** Your system will reboot to carry out a pending TPM operation.

#### Current Status Information

This item displays the status of the TPM support on this serverboard.

## ►ACPI Settings

### WHEA Support

Select Enabled to support the Windows Hardware Error Architecture (WHEA) platform and provide a common infrastructure for the system to handle hardware errors within the Windows OS environment to reduce system crashes and to enhance system recovery and health monitoring. The options are **Enabled** and Disabled.

### High Precision Timer

Select Enabled to activate the High Precision Event Timer (HPET) that produces periodic interrupts at a much higher frequency than a Real-time Clock (RTC) does in synchronizing multimedia streams, providing smooth playback and reducing the dependency on other timestamp calculation devices, such as an x86 RDTSC Instruction embedded in the CPU. The High Performance Event Timer is used to replace the 8254 Programmable Interval Timer. The options are **Enabled** and Disabled.

### NUMA (Available when the OS supports this feature)

Select Enabled to enable Non-Uniform Memory Access support to enhance system performance. The options are **Enabled** and Disabled.

## 7-4 Event Logs

Use this feature to configure Event Log settings.

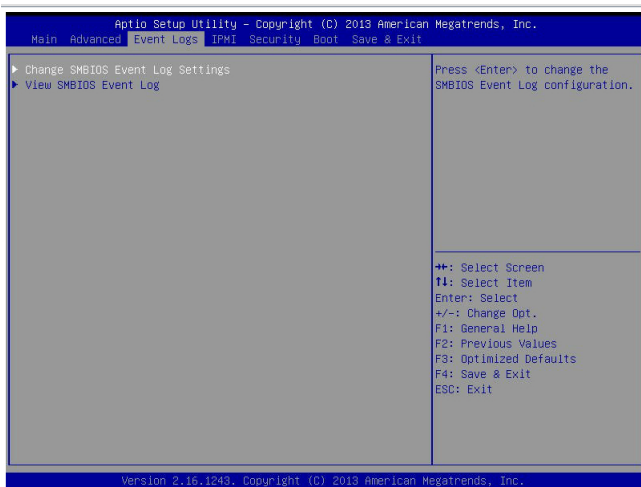

### ► Change SMBIOS Event Log Settings

This feature allows the user to configure SMBIOS Event settings.

#### Enabling/Disabling Options

##### SMBIOS Event Log

Select Enabled to enable SMBIOS (System Management BIOS) Event Logging during system boot. The options are **Enabled** and Disabled.

##### Runtime Error Logging Support

Select Enabled to support Runtime Error Logging. The options are **Enabled** and Disabled. If this item is set to Enable, the following item will be available for configuration:

##### Memory Corrected Error Enabling (Available when the item above- Runtime Error Logging Support is set to Enable)

Select Enabled for the BIOS to correct a memory error if it is correctable. The options are **Enabled** and Disabled.

##### PCI-Ex (PCI-Express) Error Enable

Select Yes for the BIOS to correct errors occurred in the PCI-E slots. The options are Yes and **No**.

### Memory Correctable Error Threshold

Use this item to enter the threshold value for correctable memory errors. The default setting is **10**.

### Erasing Settings

#### Erase Event Log

Select Enabled to erase all error events in the SMBIOS (System Management BIOS) log before an event logging is initialized at bootup. The options are **No** and Yes.

#### When Log is Full

Select Erase Immediately to immediately erase all errors in the SMBIOS event log when the event log is full. Select Do Nothing for the system to do nothing when the SMBIOS event log is full. The options are **Do Nothing** and Erase Immediately.

### SMBIOS Event Log Standard Settings

#### Log System Boot Event

Select Enabled to log system boot events. The options are **Disabled** and Enabled.

#### MECI (Multiple Event Count Increment)

Enter the increment value for the multiple event counter. Enter a number between 1 to 255. The default setting is **1**.

#### METW (Multiple Event Count Time Window)

This item is used to determine how long (in minutes) should the multiple event counter wait before generating a new event log. Enter a number between 0 to 99. The default setting is **60**.

**Note:** Please reboot the system for the changes to take effect.

### ►View SMBIOS Event Log

This item allows the user to view the event in the SMBIOS event log. Select this item and press <Enter> to view the status of an event in the log. The following categories are displayed:

Date/Time/Error Code/Severity

## 7-5 IPMI

Use this feature to configure Intelligent Platform Management Interface (IPMI) settings.

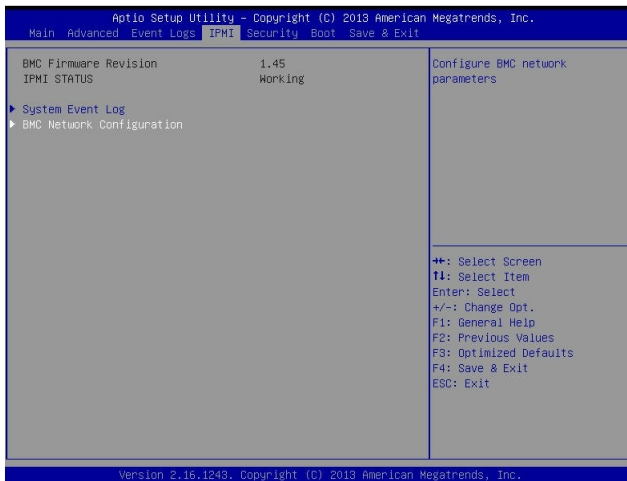

### IPMI Firmware Revision

This item indicates the IPMI firmware revision used in your system.

### IPMI Status

This item indicates the status of the IPMI firmware installed in your system.

## ► System Event Log

### Enabling/Disabling Options

#### SEL Components

Select Enabled to enable all system event logging support at bootup. The options are **Enabled** and Disabled.

#### Erasing Settings

##### Erase SEL

Select Yes, On next reset to erase all system event logs upon next system reboot.  
 Select Yes, On every reset to erase all system event logs upon each system reboot.  
 Select No to keep all system event logs after each system reboot. The options are **No**, Yes, On next reset, and Yes, On every reset.

### When SEL is Full

This feature allows the user to determine what the BIOS should do when the system event log is full. Select Erase Immediately to erase all events in the log when the system event log is full. The options are **Do Nothing** and Erase Immediately.

**Note:** After making changes on a setting, be sure to reboot the system for the changes to take effect.

## ►BMC Network Configuration

The following items will be displayed:

- IPMI LAN Selection
- IPMI Network Link Status

### Update IPMI LAN Configuration

Select Yes for the system BIOS to automatically reset the following IPMI settings at next system boot. The options are Yes and **No**.

#### **Configuration Address Source (Available when the item above - Update IPMI LAN Configuration is set to Yes)**

Use this item to select the IP address source for this computer. If Static is selected, you will need to know the IP address of this computer and enter it to the system manually in the field. If DHCP is selected, AMI BIOS will search for a DHCP (Dynamic Host Configuration Protocol) server attached to the network and request the next available IP address for this computer. The options are **DHCP** Unspecified, and Static.

#### **Station IP Address**

This item displays the Station IP address for this computer. This should be in decimal and in dotted quad form (i.e., 192.168.10.253).

#### **Subnet Mask**

This item displays the sub-network that this computer belongs to. The value of each three-digit number is separated by dots and it should not exceed 255.

#### **Station MAC Address**

This item displays the Station MAC address for this computer. Mac addresses are 6 two-digit hexadecimal numbers.

#### **Gateway IP Address**

This item displays the Gateway IP address for this computer. This should be in decimal and in dotted quad form (i.e., 192.168.10.253).

## 7-6 Security Settings

This menu allows the user to configure the following security settings for the system.

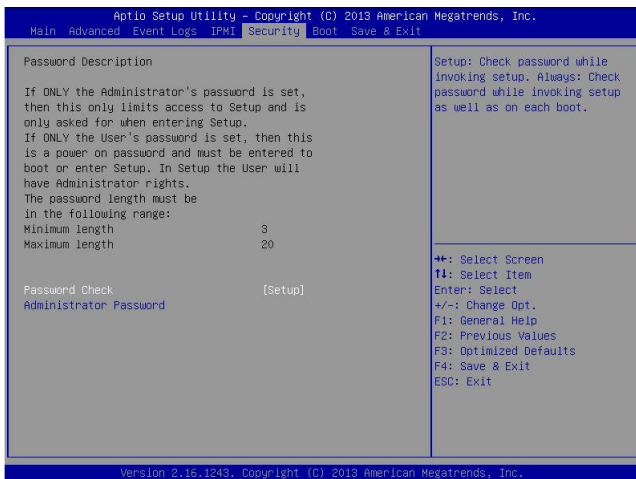

### Password Check

Select Setup for the system to prompt for a password at Setup. Select Always for the system to prompt for a password at bootup and upon entering the BIOS Setup utility. The options are **Setup** and Always.

### Administrator Password

Use this feature to set the administrator password which is required before entering the BIOS setup utility. The length of the password should be from 3 characters to 20 characters long.

### User Password

Use this feature to set the user password which is required to enter the BIOS setup utility. The length of the password should be from 3 characters to 20 characters long.



## 7-7 Boot Settings

Use this feature to configure Boot Settings:

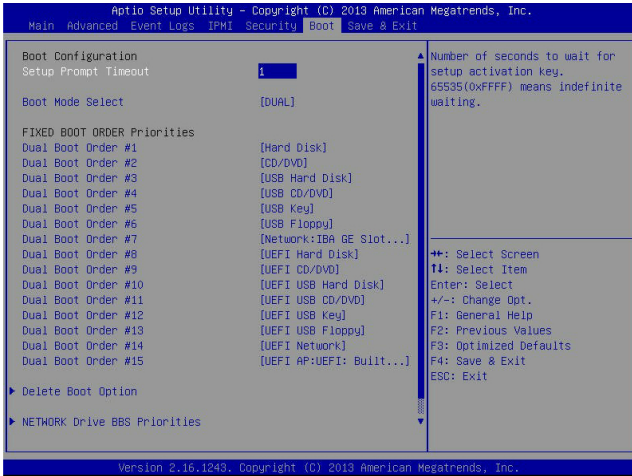

### Boot Configuration

#### Setup Prompt Timeout

Use this item to indicate how many seconds the system shall wait for the BIOS setup activation key to respond before the system starts to boot. The default setting is **1**.

#### Boot Mode Select

Use this item to select the type of device to be used for system boot. The options are Legacy, UEFI, and **Dual**.

#### Fixed Boot Order Priorities

This option prioritizes the order of bootable devices from which the system will boot. Press <Enter> on each entry from top to bottom to select devices.

- Dual Boot Order #1
- Dual Boot Order #2
- Dual Boot Order #3
- Dual Boot Order #4
- Dual Boot Order #5
- Dual Boot Order #6

- Dual Boot Order #7
- Dual Boot Order #8
- Dual Boot Order #9
- Dual Boot Order #10
- Dual Boot Order #11
- Dual Boot Order #12
- Dual Boot Order #13
- Dual Boot Order #14
- Dual Boot Order #15

### **Add New Boot Option**

This feature allows the user to add a new boot option to system boot features.

#### **Add Boot Option**

Use this item to specify the name of the driver that the new boot option is added to.

#### **Path for Boot Option**

This item is used to specify the path to the driver that the new boot option is added to. The format for the path is "fsx:\path\filename.efi".

### **Boot Option File Path**

#### **Create**

After the driver option name and the file path are set, press <Enter> to enter to submenu and click OK to create the new boot option drive.

#### **►Delete Boot Option**

Use this item to select a boot device to delete from the boot priority list.

#### **Delete Boot Option**

Select the target boot device to delete.

▶ **Network Drive BBS Priorities**

- Legacy Boot Order #1

▶ **UEFI Application Boot Priorities**

- UEFI Boot Order #1

## 7-8 Save & Exit

Select the Save & Exit tab from the BIOS setup screen to configure the settings below.



### Discard Changes and Exit

Select this option to quit the BIOS setup without making any permanent changes to the system configuration, and reboot the computer. Select Discard Changes and Exit from the Exit menu and press <Enter>.

### Save Changes and Reset

When you have completed the system configuration changes, select this option to leave the BIOS setup utility and reboot the computer for the new system configuration parameters to take effect. Select Save Changes and Exit from the Exit menu and press <Enter>.

### Save Options

#### Save Changes

When you have completed the system configuration changes, select this option to save all changes made. This will not reset (reboot) the system.

#### Discard Changes

Select this option and press <Enter> to discard all the changes and return to the AMI BIOS Utility Program.

**Restore Defaults**

To set this feature, select Restore Defaults from the Exit menu and press <Enter>. These are manufacture default settings designed for maximum system performance but not for maximum stability.

**Save As User Defaults**

To set this feature, select Save as User Defaults from the Exit menu and press <Enter>. This enables the user to save any changes to the BIOS setup for future use.

**Restore User Defaults**

To set this feature, select Restore User Defaults from the Exit menu and press <Enter>. Use this feature to retrieve user-defined settings that were saved previously.

**Boot Override**

This feature allows the user to override the Boot priorities sequence in the Boot menu, and immediately boot the system with another device specified by the user. This is a one-time override.

# Notes

## Appendix A

### BIOS Error Beep Codes

During the POST (Power-On Self-Test) routines, which are performed at each system boot, errors may occur.

**Non-fatal errors** are those which, in most cases, allow the system to continue to boot. The error messages normally appear on the screen.

**Fatal errors** will not allow the system to continue with bootup procedure. If a fatal error occurs, you should consult with your system manufacturer for possible repairs.

These fatal errors are usually communicated through a series of audible beeps. The numbers on the fatal error list correspond to the number of beeps for the corresponding error.

X10 Serverboard BIOS Error Beep Codes		
Beep Code/LED	Error Message	Description
1 beep	Refresh	Ready to boot
5 short beeps + 1 long beep	Memory error	No memory detected in the system
5 beeps	No Con-In or No Con-Out devices	Con-In includes USB or PS/2 keyboard, PCI or Serial Console Redirection, IPMI KVM or SOL.  Con-Out includes Video Controller, PCI or Serial Console Redirection, IPMI SOL.
1 beep per device	Refresh	1 beep or each USB device detected
<b>X10 IPMI Error Codes</b>		
1 Continuous Beep	System OH	System Overheat

# Notes



# Appendix B

## System Specifications

### Processors

Two Intel® E5-2600 (v3/V4) Series processors in LGA2011 sockets (Socket R)

Note: refer to our web site for details on supported processors and operating systems.

### Chipset

Intel PCH C612

### BIOS

128 MB SPI AMI BIOS® SM Flash BIOS

### Memory Capacity

Eight DIMM slots that support up to 1 TB of ECC LRDIMM (Load-Reduced DIMMs) or 512 GB of ECC RDIMM (registered DIMMs) DDR4-2400/2133/1866/1600 memory

Note: refer to Section 5-6 for details and to our web site for updates to supported memory.

### SATA

SATA controller is integrated into the chipset to provide a 10-port SATA 3.0 subsystem

### Drive Bays

Four drive bays to house 3.5" SATA drives

### PCI Expansion

One PCI-Express 3.0 x8 card may be installed to the riser card in the system (p/n RSC-RR1U-E8)

Note: refer to Section 5-6 for details.

### Serverboard

X10DRL-i

Dimensions: 12 x 10 in (305 x 254 mm)

## **Chassis**

6018R-MT: SC813MFTQ-400CB (1U Rackmount)

6018R-MTR: SC813MFTQ-R400CB (1U Rackmount)

Dimensions (both): (WxHxD) 17.2 x 1.7 x 19.85 in. (437 x 43 x 504 mm)

## **Weight**

6018R-MT: Gross Weight: 36 lbs. (16.36kg.)

6018R-MTR: Gross Weight: 38 lbs. (17.27 kg.)

## **System Cooling**

Four 4-cm high performance fans (p/n FAN-0147L4)

One air shroud (p/n MCP-310-19015-0N)

## **System Input Requirements (6018R-MT)**

AC Input Voltage: 100-240VAC auto-range

Rated Input Current: 5.5A-4A (100-240V), 3.5A-2.5A (180-240V)

Rated Input Frequency: 50 to 60 Hz

## **System Input Requirements (6018R-MTRF)**

AC Input Voltage: 100-240VAC auto-range

Rated Input Current: 100-240V, 6A-3A

Rated Input Frequency: 50 to 60 Hz

## **Power Supply (6018R-MT)**

Rated Output Power: 440-480W (Part# PWS-441P-1H)

Rated Output Voltages: +3.3V (15A), +5V (18A), +12V (38.8A at 100-140V, 39.1A at 180-240V), +5Vsb (3A)

## **Power Supply (6018R-MTRF)**

Rated Output Power: 400W (Part# PWS-406P-1R)

Rated Output Voltages: +3.3V (25A), +5V (25A), +12V (33A), -12V (.6A), +5Vsb (3A)

## **Operating Environment**

Operating Temperature: 10° to 35° C (50° to 95° F)

Non-operating Temperature: -40° to 70° C (-40° to 158° F)

Operating Relative Humidity: 20% to 95% (non-condensing)

Non-operating Relative Humidity: 5 to 95% (non-condensing)

## **Regulatory Compliance**

Electromagnetic Emissions: FCC Class A, EN 55022 Class A, EN 61000-3-2/-3-3, CISPR 22 Class A

Electromagnetic Immunity: EN 55024/CISPR 24, (EN 61000-4-2, EN 61000-4-3, EN 61000-4-4, EN 61000-4-5, EN 61000-4-6, EN 61000-4-8, EN 61000-4-11)

Safety: CSA/EN/IEC/UL 60950-1 Compliant, UL or CSA Listed (USA and Canada), CE Marking (Europe)

California Best Management Practices Regulations for Perchlorate Materials:

This Perchlorate warning applies only to products containing CR (Manganese Dioxide) Lithium coin cells. "Perchlorate Material-special handling may apply. See [www.dtsc.ca.gov/hazardouswaste/perchlorate](http://www.dtsc.ca.gov/hazardouswaste/perchlorate)"

(continued from front)

The products sold by Supermicro are not intended for and will not be used in life support systems, medical equipment, nuclear facilities or systems, aircraft, aircraft devices, aircraft/emergency communication devices or other critical systems whose failure to perform be reasonably expected to result in significant injury or loss of life or catastrophic property damage. Accordingly, Supermicro disclaims any and all liability, and should buyer use or sell such products for use in such ultra-hazardous applications, it does so entirely at its own risk. Furthermore, buyer agrees to fully indemnify, defend and hold Supermicro harmless for and against any and all claims, demands, actions, litigation, and proceedings of any kind arising out of or related to such ultra-hazardous use or sale.